

Robacta 300

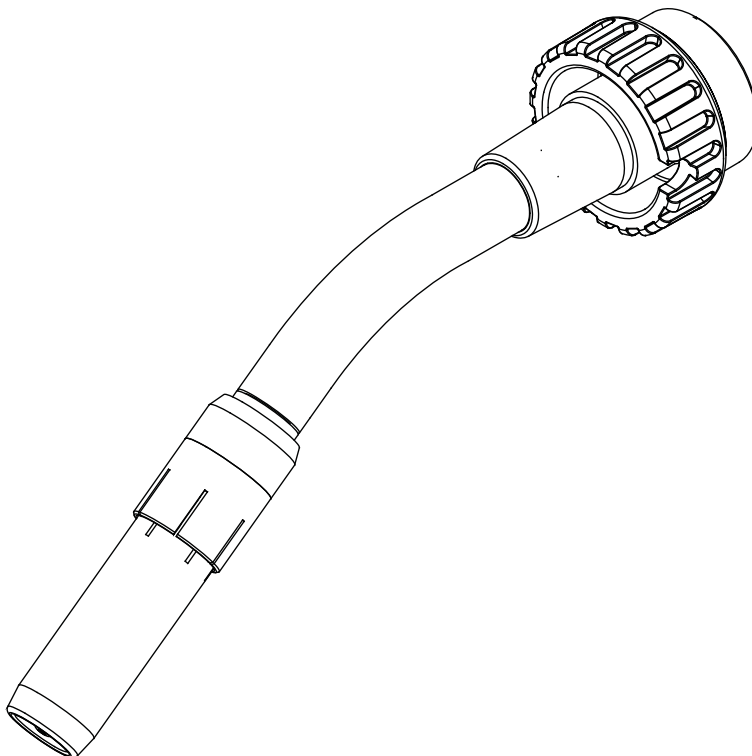

(D) Ersatzteilliste
MIG/MAG-Roboter-Rohrbogen

(GB) Spare Parts List
MIG/MAG Robot torch body

(F) Liste de pièces de rechange
corps de chalumeau robot
MIG/MAG

(I) Lista parti di ricambio
curva robot MIG/MA

(E) Lista de repuestos
Codo de tubo para robot
MIG/MAG

(P) Lista de peças sobresselentes
Queimador de soldadura robot
MIG/MAG

34,0350,1679 Robacta 300 0° L=250mm (9.843inch)
34,0350,1781 Robacta 300 22° L=241mm (9.488inch) H=50mm (1.969inch)
34,0350,1924 Robacta 300 22° L=241mm (9.488inch) H=50mm (1.969inch) geschr.
34,0350,1886 Robacta 300 22° L=324mm (12.756inch) H=50mm (1.969inch)
34,0350,1903 Robacta 300 22° L=382mm (15.039inch) H=50mm (1.969inch)
34,0350,1680 Robacta 300 36° L=224mm (8.819inch) H=86mm (3.386inch)
34,0350,1893 Robacta 300 45° L=209mm (8.228inch) H=107mm (4.213inch)

34,0350,1679,630 Robacta 300 0° OVT L=250mm (9.843inch)
34,0350,1781,630 Robacta 300 22° OVT L=241mm (9.488inch) H=50mm (1.969inch)
34,0350,1886,630 Robacta 300 22° OVT L=324mm (12.756inch) H=50mm (1.969inch)
34,0350,1903,630 Robacta 300 22° OVT L=382mm (15.039inch) H=50mm (1.969inch)
34,0350,1680,630 Robacta 300 36° OVT L=224mm (8.819inch) H=86mm (3.386inch)
34,0350,1893,630 Robacta 300 45° OVT L=209mm (8.228inch) H=107mm (4.213inch)



Robacta 300, Robacta 300 OVT

Ersatzteilliste / Spare parts list / Listes de pièces de rechange / Lista de repuestos / Lista de peças sobresselentes / Lista dei Ricambi

1/4

ROBACTA 300 - Verschleissteile (Wearing Parts)

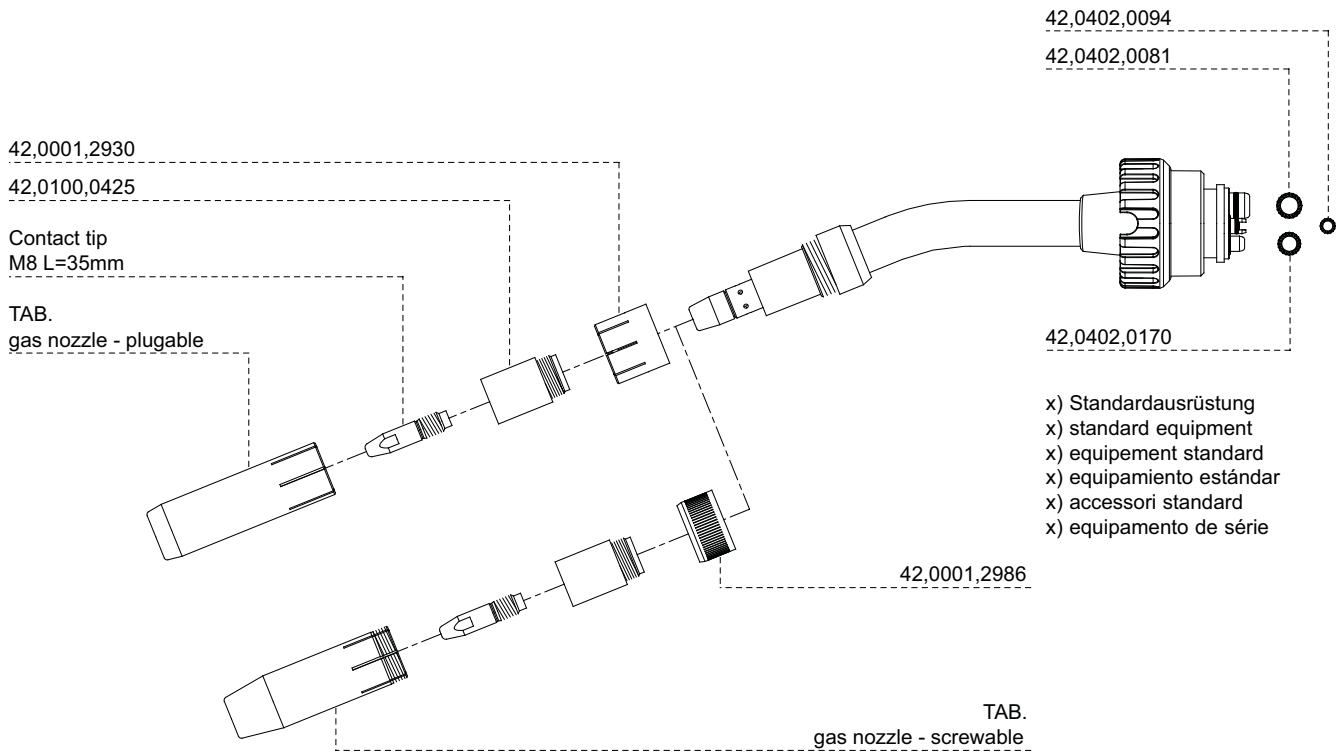

TAB. gas nozzle plugable	d1		d2		d3		L		Part No.
	mm	inch	mm	inch	mm	inch	mm	inch	
	11	.433	22	.866	14	.551	67	2.638	42,0001,5160
	13	.512	22	.866	16	.630	67	2.638	42,0001,2932
	13	.512	22	.866	16	.630	72	2.835	42,0001,2931
	15,2	.598	22	.866	19	.748	72	2.835	42,0001,2933 x)
	15,5	.610	22	.866	17	.669	65	2.559	42,0001,5083

TAB. gas nozzle screwable	d1		d2		d3		L		Part No.
	mm	inch	mm	inch	mm	inch	mm	inch	
	13	.512	22	.866	16	.630	70,5	2.776	42,0001,5214
	15,2	.598	22	.866	19	.748	72	2.835	42,0001,2985



Robacta 300, Robacta 300 OVT

Ersatzteilliste / Spare parts list / Listes de pièces de rechange / Lista de repuestos / Lista de peças sobresselentes / Lista dei Ricambi

ROBACTA 300 - Standard

42,0405,0561

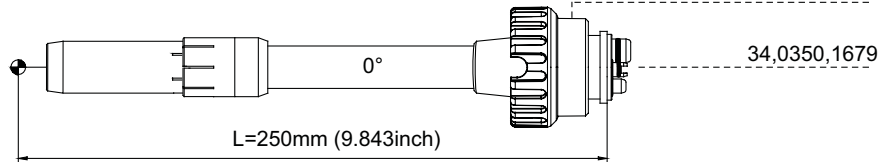

42,0405,0561

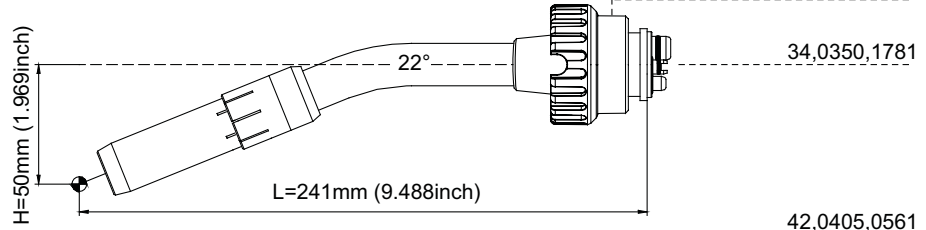
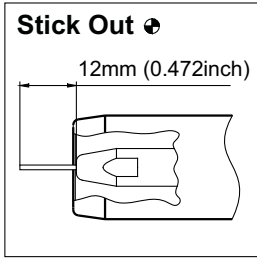

42,0405,0561

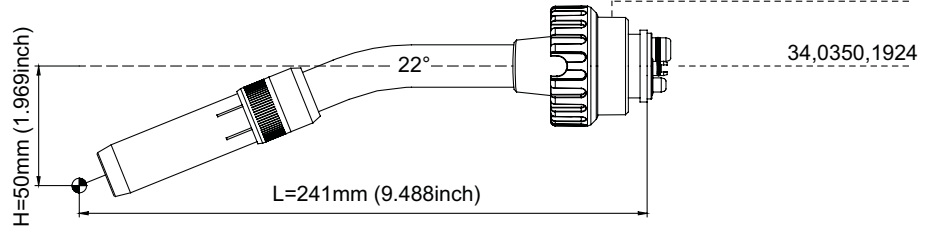

42,0400,1019

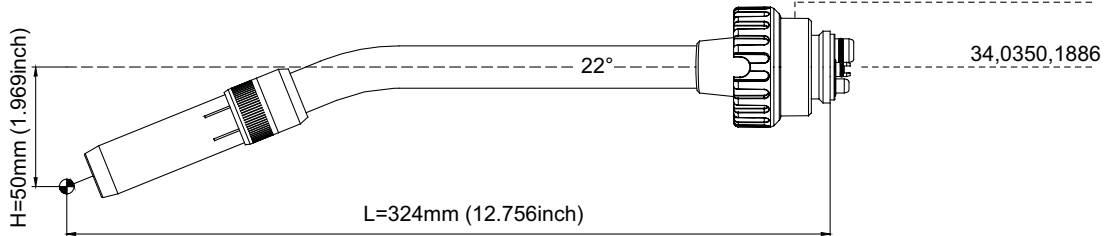

42,0400,1019

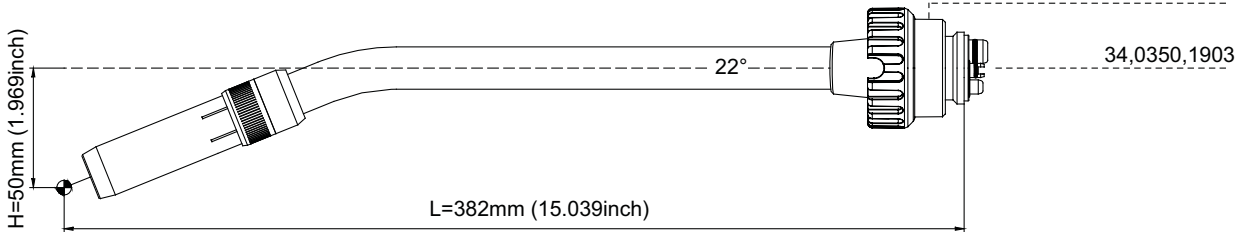

42,0405,0561

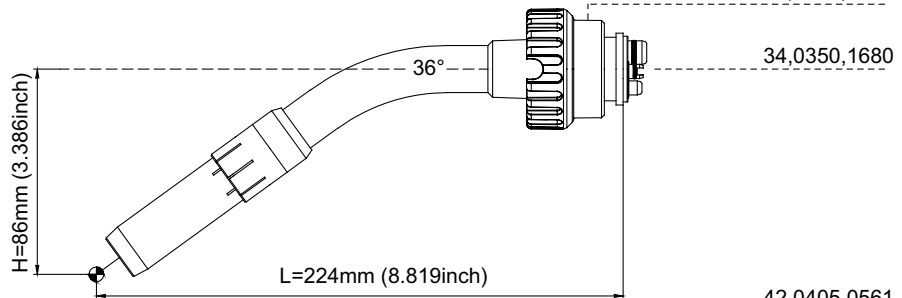

42,0405,0561

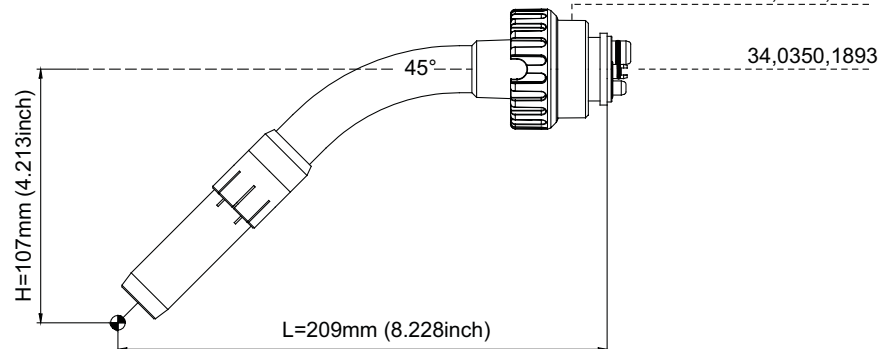

Robacta 300, Robacta 300 OVT

Ersatzteilliste / Spare parts list / Listes de pièces de rechange / Lista de repuestos / Lista de peças sobresselentes / Lista dei Ricambi

ROBACTA 300 - OVT (OVT = Ohne Verschleissteile / Without Wearing Parts)

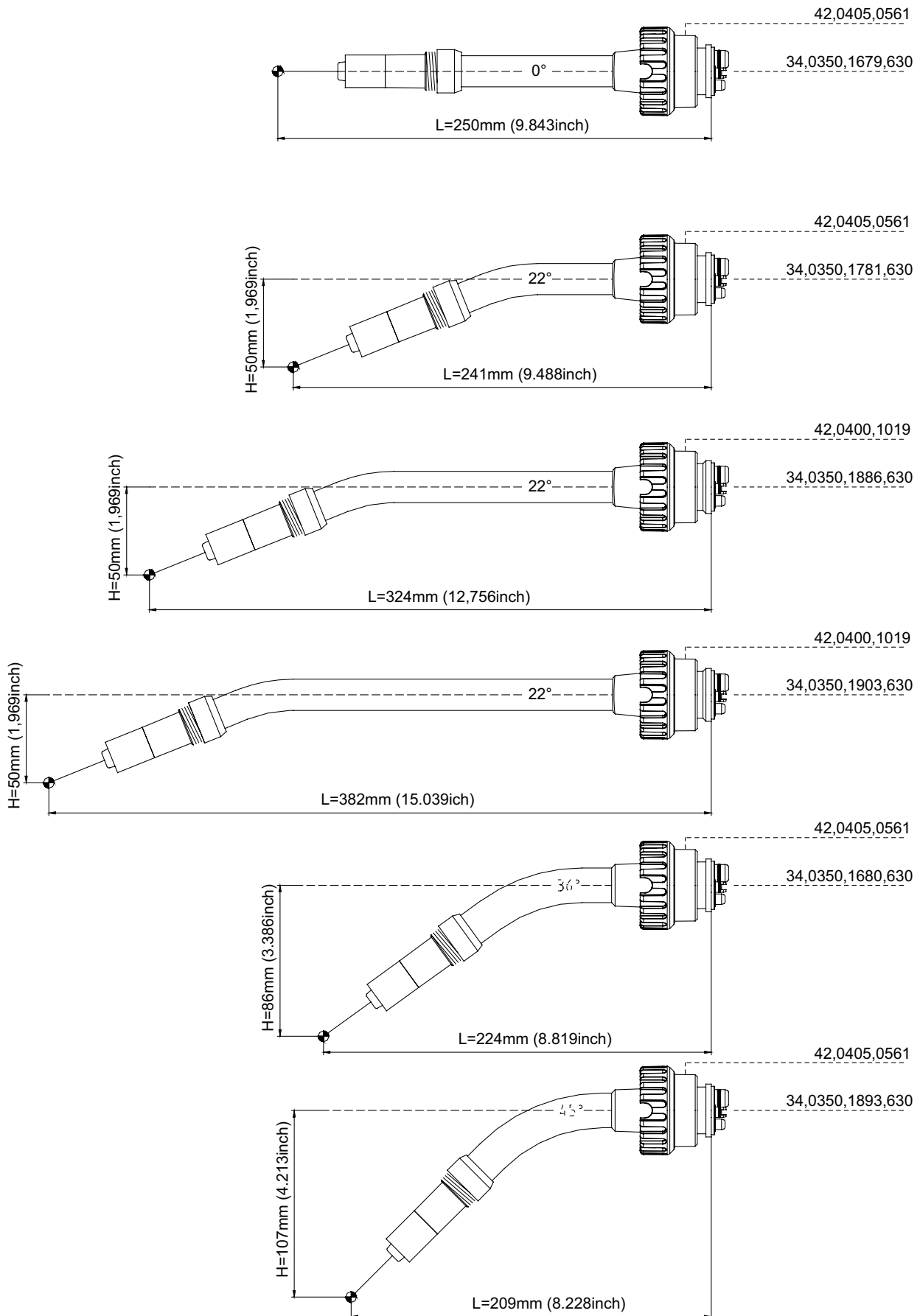

Robacta 300, Robacta 300 OVT

Ersatzteilliste / Spare parts list / Listes de pièces de rechange / Lista de repuestos / Lista de peças sobresselentes / Lista dei Ricambi

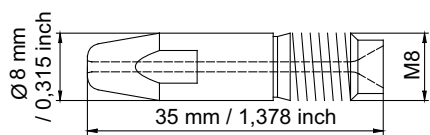
M8 / CuCrZr / L=35 mm (1,378 inch)	 Fe / CrNi		Part No.
	Ø mm	Ø inch	
	0,8	.031	42,0001,2911
	0,9	.035	42,0001,3082
	1,0	.039	42,0001,2912
	1,2	.047	42,0001,2913

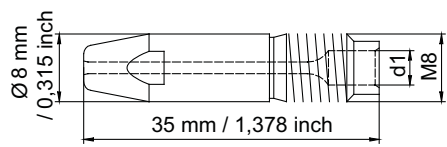
M8 / CuCrZr / L=35 mm (1,378 inch)	 Al CuSi		d1		Part No.
	Ø mm	Ø inch	Ø mm	Ø inch	
	0,8	.031	3,9	.154	42,0001,5082
	1,0	.039	4,1	.161	42,0001,5051
	1,2	.047	4,1	.161	42,0001,5052
	1,4	.055	4,1	.161	42,0001,5053
	1,6	.063	4,8	.189	42,0001,3485



Contact tip M8

Ersatzteilliste / Spare parts list / Listes de pièces de rechange / Lista de repuestos / Lista de peças sobresselentes / Lista dei Ricambi

ZUBEHÖR ROBACTA (ACCESSORY)

Robacta & Robacta Twin

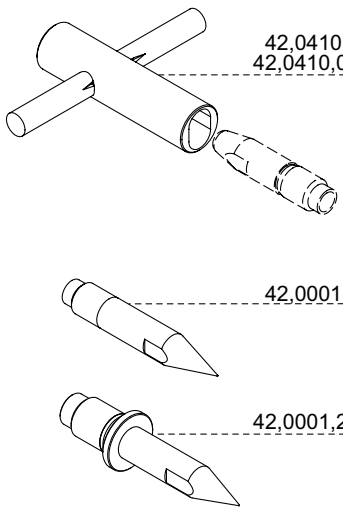

42,0410,0570-M8
42,0410,0138-M10

42,0001,2946-M8

42,0001,2920-M10

Robacta Twin

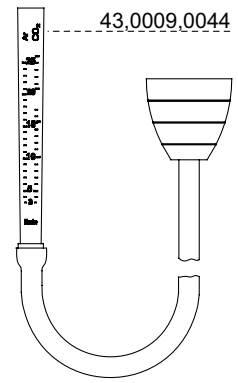

43,0009,0044

Robacta

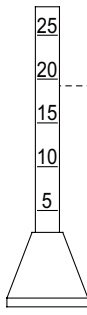

43,0009,0007

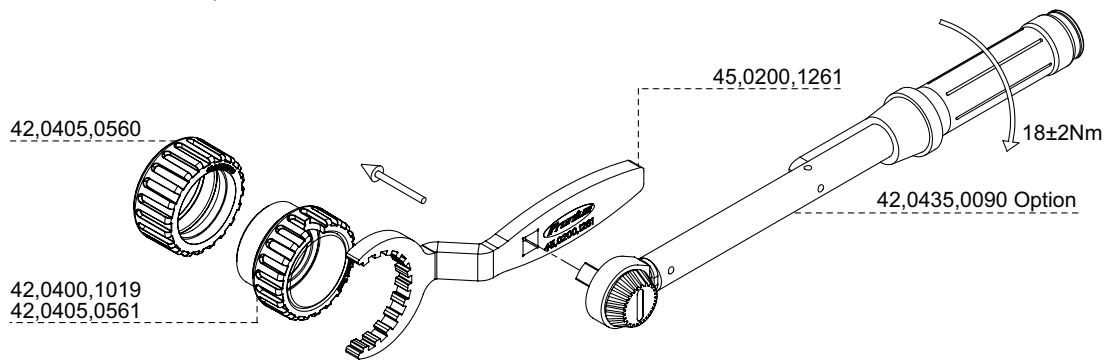

42,0405,0560

42,0400,1019
42,0405,0561

45,0200,1261

18±2Nm

42,0435,0090 Option

4,100,543 Touch Sensing Set

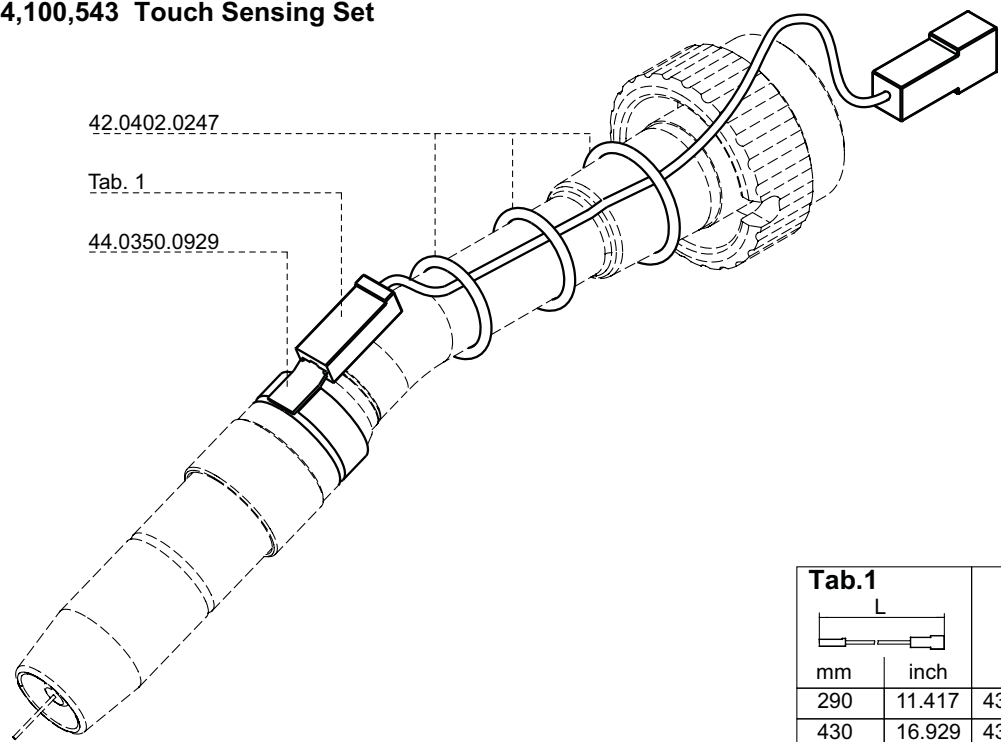

42,0402,0247

Tab. 1



44,0350,0929

mm		Part No.
mm	inch	
290	11.417	43.0004.3877
430	16.929	43.0004.3878

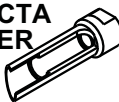

Accessories Robacta

Ersatzteilliste / Spare parts list / Listes de pièces de rechange / Lista de repuestos / Lista de peças sobresselentes / Lista dei Ricambi

Gas nozzle milling tool			ROBACTA REAMER 	
Type	 Ømm	 Øinch	Part No.	
Robacta 280	13	.512	44,0450,1158	+
	15	.591	44,0450,1385	+
Robacta 280 H	13	.512	44,0450,1158	+
	15	.591	44,0450,1159	++
Robacta 2500	10	.394	not possible	-
	12	.472	not available	-
	17	.669	44,0450,1161	+
Robacta 300	11	.433	not available	-
	13	.512	44,0450,1158	+
	15,2	.598	44,0450,1159	++
Robacta 400	11	.433	not available	-
	13	.512	44,0450,1158	+
	15,2	.598	44,0450,1385	+
Robacta 500	13	.512	not possible	-
	15	.591	44,0450,1160	+
	17,2	.677	44,0450,1255	++
Robacta 5000	13	.512	not possible	-
	15,2	.598	44,0450,1160	+
	17	.669	44,0450,1161	+
	17,2	.677	44,0450,1161	+
Robacta 5000H	13	.512	not possible	-
	20	.787	not available	-
Robacta 5000H	17	.669	44,0450,1161	++
Robacta 700	17	.669	44,0450,1255	++
Robacta 7000	17,2	.677	44,0450,1161	+

Robacta 900 Twin	14	.551	44,0450,1162	+
	18	.709	44,0450,1163	o
Robacta 900 Twin Compact	18	.709	44,0450,1163	o

Robacta MTG 2500	13	.512	44,0450,1158	+
	15	.591	44,0450,1159	++
Robacta MTG 3200	15	.591	44,0450,1385	+
Robacta MTG 4000	15	.591	44,0450,1160	+
	17	.669	44,0450,1255	++

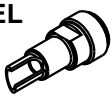
BINZEL 	
Part No.	
42,0001,5020	+
42,0001,5019	o
42,0001,5020	+
42,0001,3585	+
not possible	-
not available	-
42,0001,2996	o
not available	-
42,0001,5020	+
42,0001,3585	++
42,0001,3585	++
not available	-
42,0001,5020	+
42,0001,5019	o
42,0001,2996	o
not possible	-
42,0001,5019	+
42,0001,5545	++
not possible	-
42,0001,5019	+
42,0001,2996	+
not available	-
42,0001,2996	+
42,0001,5545	++
42,0001,5545	o

not possible	-
not possible	-
not possible	-

42,0001,5020	+
42,0001,3585	++
42,0001,5019	o
42,0001,5019	+
42,0001,5545	++

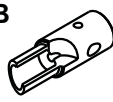
ABB 	
Part No.	
42,0001,5315	+
42,0001,5317	o
42,0001,5315	+
42,0001,5317	++
not possible	-
42,0001,5316	o
42,0001,5314	o
42,0001,5316	o
42,0001,5315	+
42,0001,5317	++
42,0001,5317	++
42,0001,5316	o
42,0001,5315	+
42,0001,5317	o
42,0001,5314	o
not possible	-
42,0001,5317	o
42,0001,5314	++
not possible	-
42,0001,5317	o
42,0001,5314	o
not available	-
42,0001,5314	+
42,0001,5314	++
42,0001,5314	o

not possible	-
not possible	-
not possible	-

42,0001,5315	+
42,0001,5317	++
42,0001,5317	o
42,0001,5317	o
42,0001,5314	++

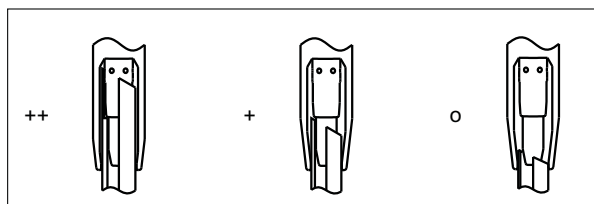

Gas nozzle milling tool



Gas nozzle milling tool

Ersatzteilliste / Spare parts list / Listes de pièces de rechange / Lista de repuestos / Lista de peças sobresselentes / Lista dei Ricambi

Examination device Robacta long

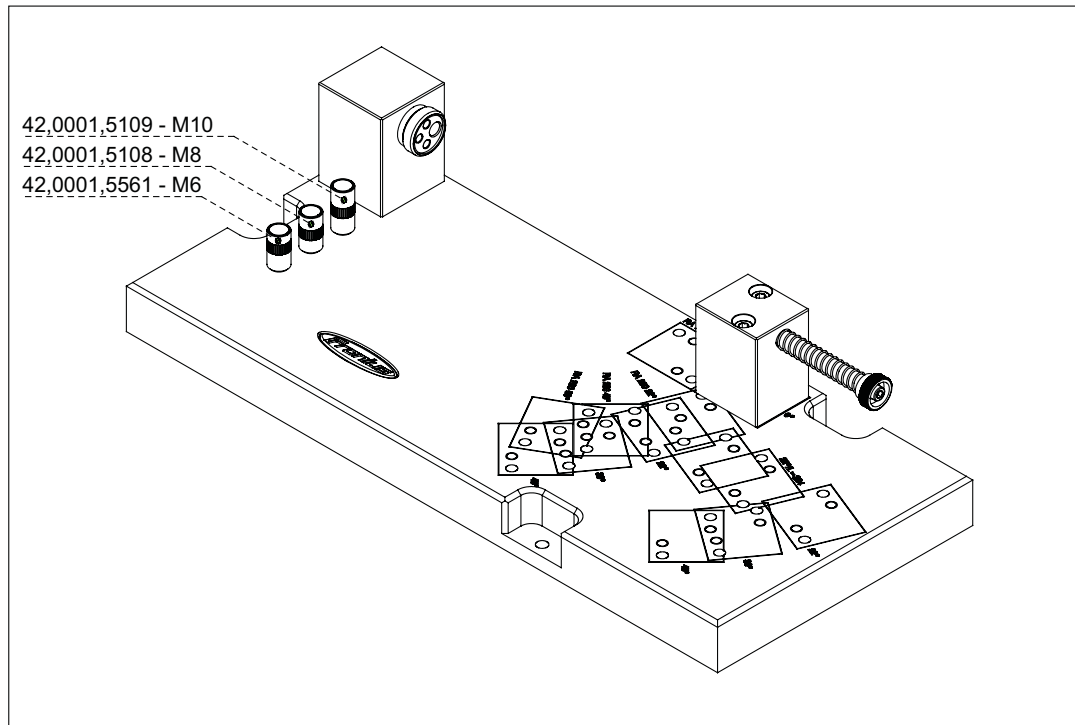

44,0360,0063

Been suitable for this Robacta types:

Type	Degree	Length	
		mm	inch
Robacta 160	0°	224,5	8,839
	22°	218,5	4,240
	45°	212,5	1,575
Robacta 280	0°	250	9,843
	22°	246	9,685
	45°	228,5	8,996
	60°	212,5	8,366
Robacta 300 Robacta 400	0°	250	9,843
	22°	241	9,488
	22°	324	12,756
	22°	382	15,039
	36°	224	8,819
Robacta 500	45°	209	8,228
	0°	250	9,843
	22°	241	9,488
	22°	383	15,079
	36°	224	8,819
Robacta 700 Robacta 7000	36°	366	14,409
	45°	209	8,228
	45°	351	13,819
	0°	187,5	7,382
	0°	250	9,843
	0° (Time)	258	10,157
	22°	241	9,488
36°	224	8,819	
Robacta 2500	36° (Time)	230,5	9,075
	45°	209	8,228
	22°	241	9,488
Robacta 5000	36°	224	8,819
	45°	209	8,228
	45°	351	13,819
	0°	250	9,843
	22°	241	9,488
	22°	383	15,079



Examination device Robacta long

Ersatzteilliste / Spare parts list / Listes de pièces de rechange / Lista de repuestos / Lista de peças sobresselentes / Lista dei Ricambi

1 / 1

Correcting device Robacta (Basic Kit)

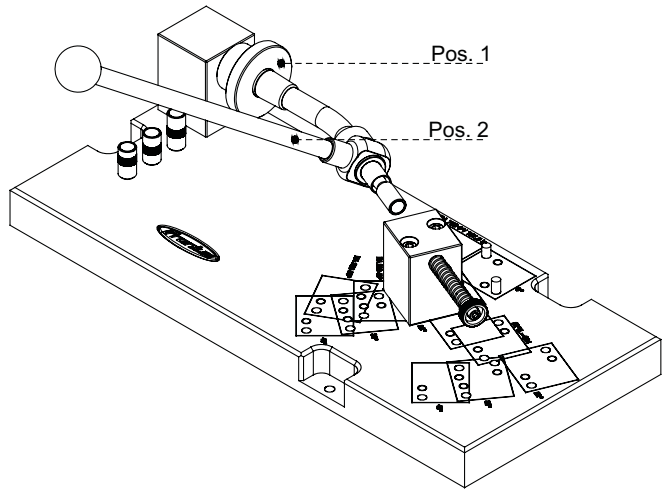
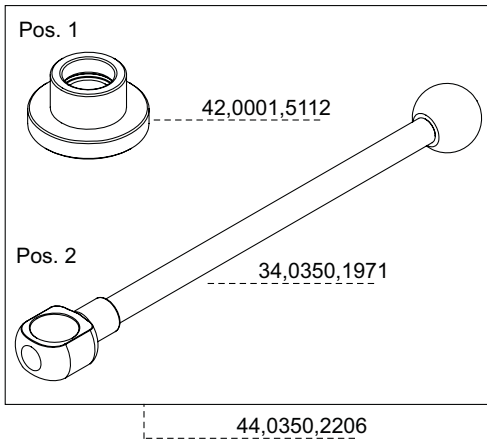

Correcting Set's

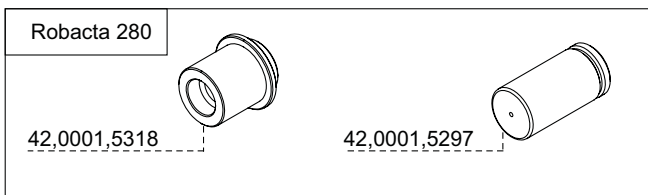

44,0350,1963 - Set

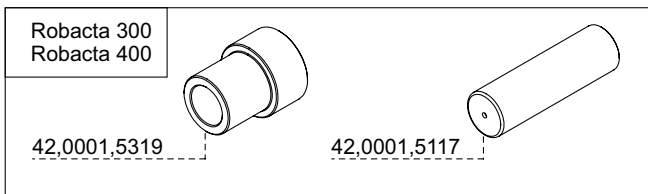

44,0350,1646 - Set

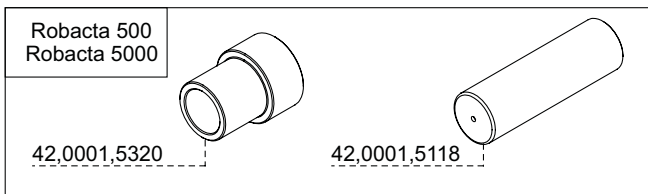

44,0350,1647 - Set

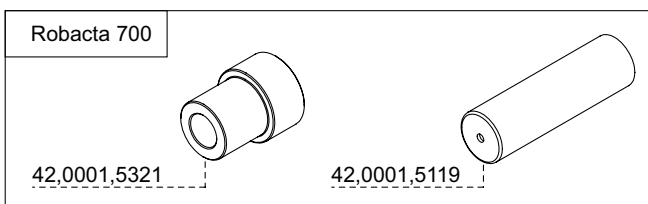

44,0350,1648 - Set

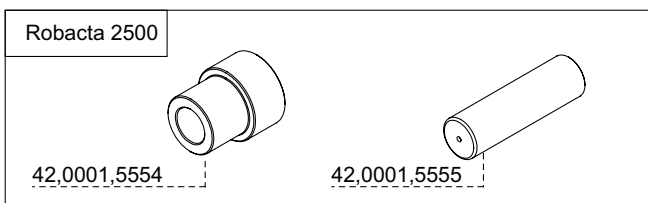

44,0350,2223 - Set

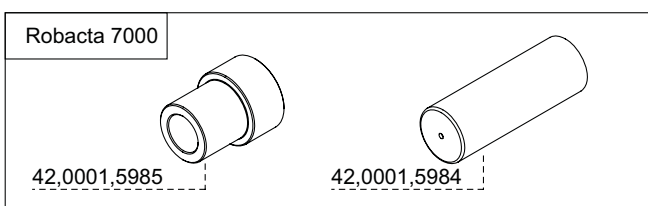

44,0350,2630 - Set

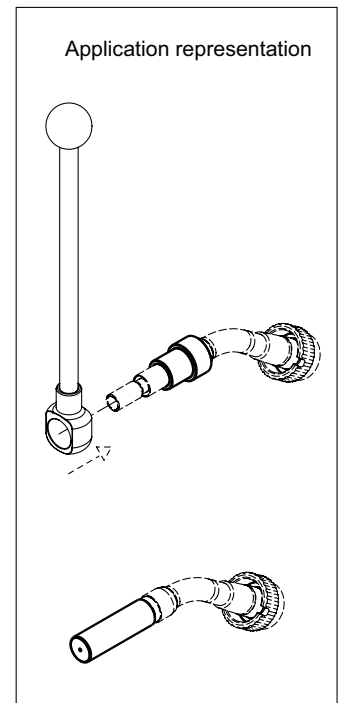

Robacta adjusting device

Ersatzteilliste / Spare parts list / Listes de pièces de rechange / Lista de repuestos / Lista de peças sobresselentes / Lista dei Ricambi



FRONIUS INTERNATIONAL GMBH

Buxbaumstraße 2, A-4600 Wels, Austria

Tel: +43 (0)7242 241-0, Fax: +43 (0)7242 241-3940

E-Mail: sales@fronius.com

www.fronius.com

www.fronius.com/addresses

Under <http://www.fronius.com/addresses> you will find all addresses
of our Sales & service partners and Locations.