

MIG/MAG Welding Torches ABIMIG® A T 305 LW

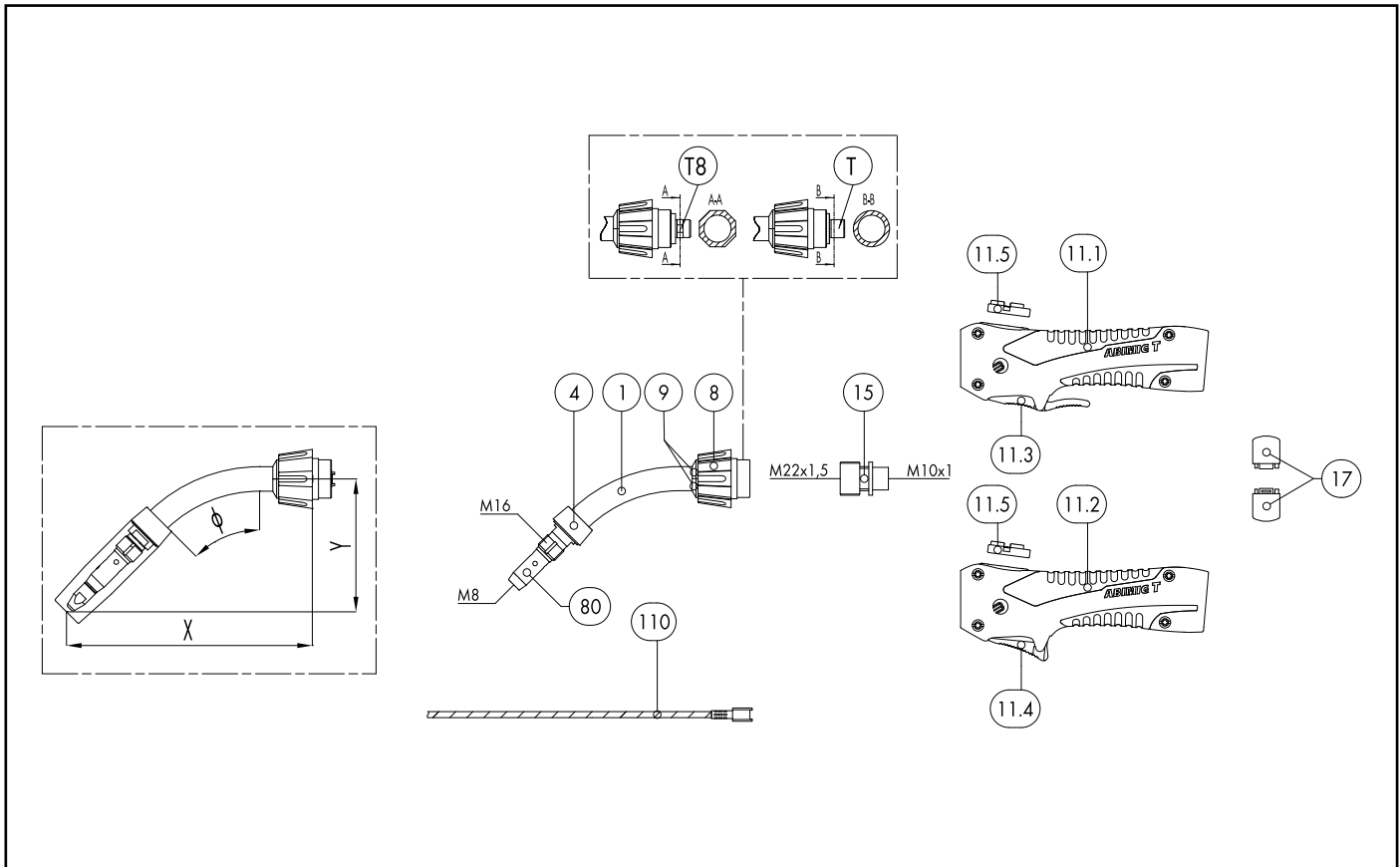

Pos.	Description	Units	Part-No.	Product-group
Basic torch (complete)				
	ABIMIG® A T 305 LW; TM45°; central adaptor KZ-2; 3.00 m		018.D960.1	1324
	ABIMIG® A T 305 LW; TM45°; central adaptor KZ-2; 4.00 m		018.D961.1	1324
	ABIMIG® A T 305 LW; TM45°; central adaptor KZ-2; 5.00 m		018.D962.1	1324
Combi torch (basic torch without neck and wear parts)				
	ABIMIG® A T G 305 LW; central adaptor KZ-2; 3.00 m		018.D978.1	1326
	ABIMIG® A T G 305 LW; central adaptor KZ-2; 4.00 m		018.D979.1	1326
	ABIMIG® A T G 305 LW; central adaptor KZ-2; 5.00 m		018.D980.1	1326
Swan neck				
1	Swan neck ABIMIG® A T 305K TM; 45°; X=130; Y=85		014.H403.1	1308
1	Swan neck ABIMIG® A 305 LW; 45° bent		014.H356.1	1308
1	Swan neck ABIMIG® A 355 LW; 45° bent		014.H363.1	1308
1	Swan neck ABIMIG® A T 305/355 T8M; 45°; X=185; Y=95		014.H370.1	1308
1	Swan neck ABIMIG® A T 305/355 TM; 45°; X=350; Y=95		014.H374.1	1308
1	Swan neck ABIMIG® A T 305/355 TM; 45°; X=500; Y=95		014.H380.1	1308
1	Swan neck ABIMIG® A T 305/355 TM; 60°; X=165; Y=110		014.H413.1	1308
1	Swan neck ABIMIG® A T 305/355 T8M; 60°; X=165; Y=110		014.H415.1	1308
1	Swan neck ABIMIG® A T 305K T8M; 45°; X=135; Y=75		014.H583.1	1308
1	Swan neck ABIMIG® A T 305/355K T8M; 45°; X=0160; Y=85		014.H588.1	1308
1	Swan neck ABIMIG® A T 355 T8M; 45°; X=350; Y=95		014.H555.1	1308
1	Swan neck ABIMIG® A T 355 T8M; 45°; X=500; Y=95		014.H560.1	1308
	Swan neck ABIMIG® A T 307K TM; 45°; X=135; Y=85; gas nozzle mated		014.H409.1	1308
	Swan neck ABIMIG® A T 307/357K TM; 45°; X=160; Y=85; gas nozzle mated		014.H387.1	1308
	Swan neck ABIMIG® A T 307/357 TM; 45°; X=185; Y=95; gas nozzle mated		014.H388.1	1308
	Swan neck ABIMIG® A T 307/357 T8M; 45°; X=185; Y=95; gas nozzle mated		014.H389.1	1308
	Swan neck ABIMIG® A T 307K T8M; 45; X=135; Y=85; gas nozzle mated		014.H587.1	1308

MIG/MAG Welding Torches ABIMIG® A T 305 LW

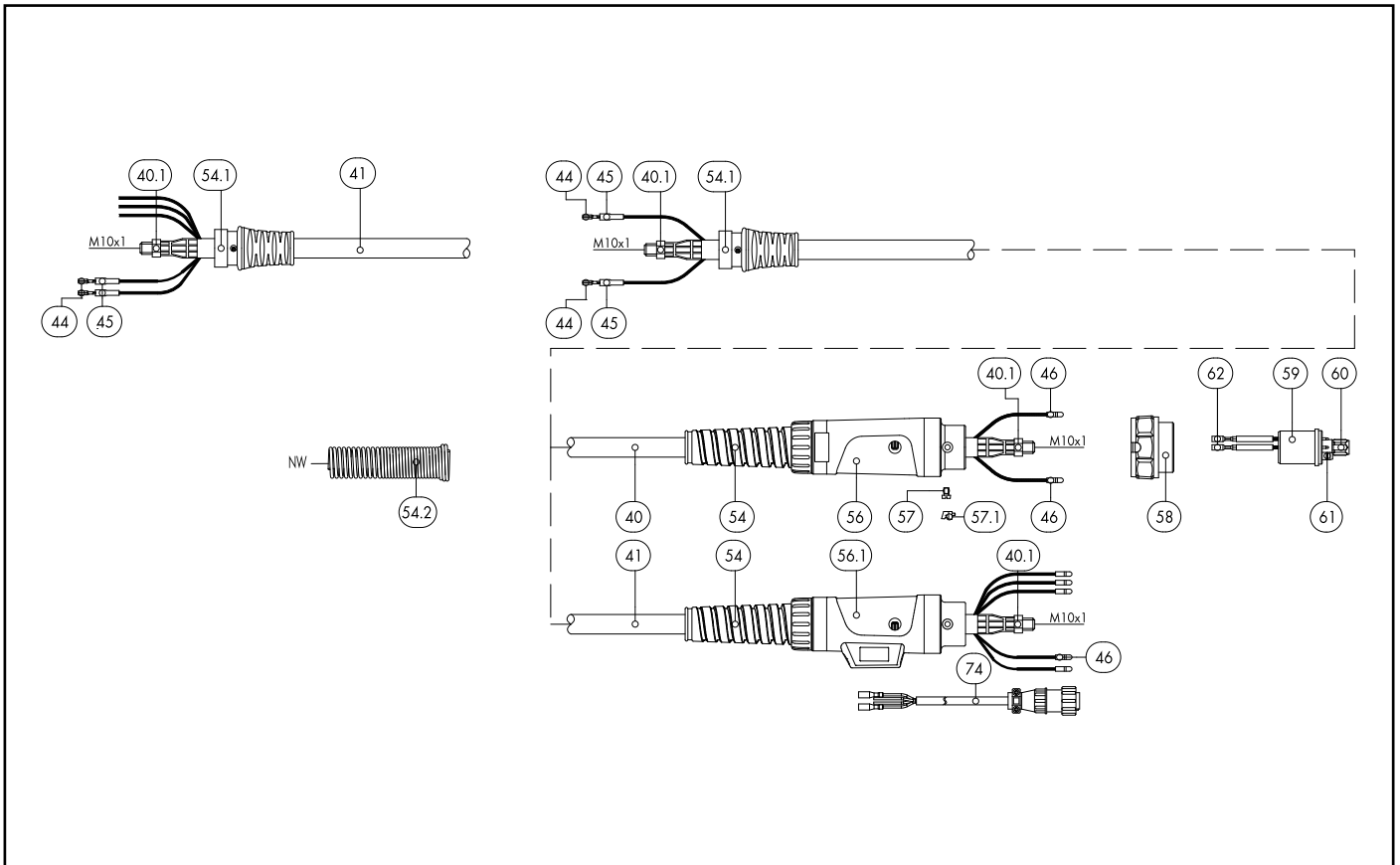

Pos.	Description	Units	Part-No.	Product-group
	Swan neck ABIMIG® A T 307/357K T8M; 45°; X=160, Y=85; gas nozzle mated		014.H592.1	1308
	Swan neck ABIMIG® A T 307/357K TM; 45°; X=165, Y=110; gas nozzle mated		014.H594.1	1308
	Swan neck ABIMIG® A T 307/357K T8M; 45°; X=165, Y=110; gas nozzle mated		014.H596.1	1308
	Swan neck ABIMIG® A T 357 T8M; 45°; X=360, Y=95; gas nozzle mated		014.H597.1	1308
	Swan neck ABIMIG® A T 357 TM; 45°; X=500, Y=95; gas nozzle mated		014.H398.1	1326
	Swan neck ABIMIG® A T 357 T8M; 45°; X=500; Y=95; gas nozzle mated		014.H399.1	1326
	Swan neck ABIMIG® A T 305 T8 FLEX; X=260		018.D801	1308
	COMBI swan neck A T 305K TM cpl.; 45°; X=135, Y=75; gas nozzle screwed		014.0467.1	1308
	COMBI swan neck A T 305K T8M cpl.; 45°; X=135, Y=75; gas nozzle screwed		014.0468.1	1308
	COMBI swan neck A T 305/355K TM cpl.; 45°; X=160, Y=85; gas nozzle screwed		014.0469.1	1308
	COMBI swan neck A T 305/355K T8M cpl.; 45°; X=160, Y=85; gas nozzle screwed		014.0470.1	1308
	COMBI swan neck A T 305/355K TM cpl.; 60°; X=165, Y=110; gas nozzle screwed		014.0471.1	1308
	COMBI swan neck A T 305/355K T8M cpl.; 60°; X=165, Y=110; gas nozzle screwed		014.0472.1	1308
	COMBI swan neck A T 305/355K TM cpl.; 45°; X=185, Y=95; gas nozzle screwed		014.0473.1	1308
	COMBI swan neck A T 305/355K T8M cpl.; 45°; X=185, Y=95; gas nozzle screwed		014.0474.1	1308
	COMBI swan neck A T 305XL TM cpl.; 45°; X=350, Y=95; gas nozzle screwed		014.0475.1	1308
	COMBI swan neck A T 305XL T8M cpl.; 45°; X=350, Y=95; gas nozzle screwed		014.0476.1	1308
	COMBI swan neck A T 305XXL TM cpl.; 45°; X=500, Y=95; gas nozzle screwed		014.0477.1	1308
	COMBI swan neck A T 305XXL T8M cpl.; 45°; X=500, Y=95; gas nozzle screwed		014.0478.1	1308
	COMBI swan neck A T 305 T8 FLEX cpl.; X=260; gas nozzle screwed		018.0191.1	1308
4	Spacer	5 Pcs.	767.D668.5	1595
4	Spacer HD	5 Pcs.	767.D898.5	1595
8	Coupling nut M22x1.5		014.H279.1	1595
9	Protective cab (split) D=16 for round-neck nut	10 Pcs.	014.H282.10	1595
Handle				
11.1	Handle ABIMIG® A T with push-button long		180.D077.1	1595

MIG/MAG Welding Torches ABIMIG® A T 305 LW

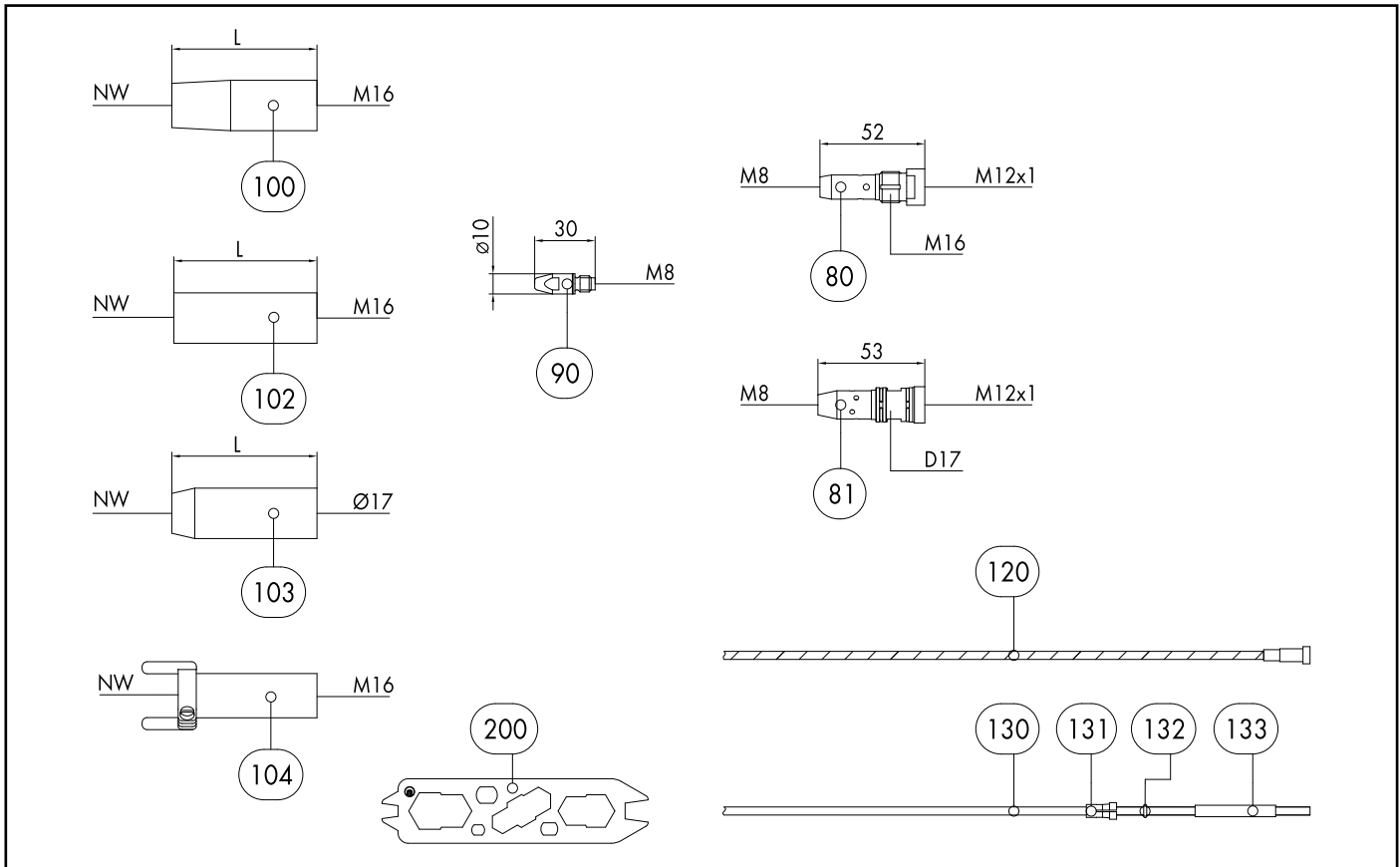

Pos.	Description	Units	Part-No.	Product-group
11.1	Handle ABIMIG® A T with push-button long (without module BIS-52)		180.D079.1	1595
11.2	Handle ABIMIG® A T with push-button short		180.D078.1	1595
11.2	Handle ABIMIG® A T with push-button short (without module BIS-52)		180.D080.1	1595
11.3	Trigger long 2-pole		185.D118.1	1595
11.4	Trigger short 2-pole		185.D120.1	1595
11.5	Blind cover		400.D573.1	1595
15	Torch pipe connection M22x1.5 / M10x1		014.H354.1	1595
17	Half rings (1 pair)	2 Pcs.	400.D561.2	1595
Cable assembly				
40	Bikox® LW power cable, R6 for 3.00 m		160.H039.1	1511
40	Bikox® LW power cable, R6 for 4.00 m		160.H040.1	1511
40	Bikox® LW cable assembly, R6 2-pole for 4.50 m		160.H378.1	1511
40	Bikox® LW power cable, R6 for 5.00 m		160.H041.1	1511
40	Bikox® LW cable assembly, R6 2-pole for 6.00 m		160.H436.1	1511
40	Bikox® LW cable assembly, R6 5-pole Up/Down for 3.00 m		160.H371.1	1511
40	Bikox® LW cable assembly, R6 5-pole Up/Down for 4.00 m		160.H372.1	1511
40	Bikox® LW cable assembly, R6 5-pole Up/Down for 4.50 m		160.H437.1	1511
40	Bikox® LW cable assembly, R6 5-pole Up/Down for 5.00 m		160.H373.1	1511
40	Bikox® LW cable assembly, R6 5-pole Up/Down for 6.00 m		160.H438.1	1511
40.1	Hexagon nut M10x1	10 Pcs.	001.0009	9010
44	Trigger wire connector	20 Pcs.	175.0022	9010
45	Insulating sleeve	20 Pcs.	400.0119	1095
46	Plug	20 Pcs.	175.0004	9010
54	Cable support NW 21		400.D518.1	1595
54.1	Cable support ABIMIG® A T LW (short)		400.D574.1	1595
54.1	Cable support spring NW 22		400.D501.1	1595

MIG/MAG Welding Torches ABIMIG® A T 305 LW

Pos.	Description	Units	Part-No.	Product-group
56	Cable support machine side		501.2248	9010
56.1	Connection housing machine side cpl.; for UNI-plug		501.D578.1	1595
57	Pan head screw M4x6	20 Pcs.	000.0552	9010
57.1	Screw cap 1	20 Pcs.	500.0251	9010
58	Adaptor nut M33x2		500.0213	9010
59	Central adaptor KZ-2		501.0003	1095
60	Coupling nut M10x1, plastic	5 Pcs.	501.D536.5	1595
61	O-Ring 4x1	20 Pcs.	165.0002	9010
62	Trigger wire connector; female	20 Pcs.	175.0003	9010
74	Control cable with 4-pole Amphenol plug L=400 mm		175.D098	1595
74.1	Protective tube 4.5x0.5, L=60 mm		110.D023	1595
Wear parts				
80	Contact tip holder M16/M8/52 US	5 Pcs.	014.D745.5	1533
81	Contact tip holder D17/M8/53 for slip-on gas nozzle	5 Pcs.	014.H129.5	1533
	Contact tip holder D17/M8/51 cpl.; for pluggable gas nozzle XX7	5 Pcs.	014.H194.5	1533
90	Contact tip M8 E-Cu; Ø 0.8 (10x30)	10 Pcs.	140.0114	1030
90	Contact tip M8 E-Cu; Ø 1.0 (10x30)	10 Pcs.	140.0313	1030
90	Contact tip M8 E-Cu; Ø 1.2 (10x30)	10 Pcs.	140.0442	1030
90	Contact tip M8 E-Cu; Ø 1.4 (10x30)	10 Pcs.	140.0533	1030
90	Contact tip M8 E-Cu; Ø 1.6 (10x30)	10 Pcs.	140.0587	1030
90	Contact tip M8 CuCrZr; Ø 0.8 (10x30)	10 Pcs.	140.0117	1031
90	Contact tip M8 CuCrZr; Ø 1.0 (10x30)	10 Pcs.	140.0316	1031
90	Contact tip M8 CuCrZr; Ø 1.2 (10x30)	10 Pcs.	140.0445	1031
90	Contact tip M8 CuCrZr; Ø 1.4 (10x30)	10 Pcs.	140.0536	1031
90	Contact tip M8 CuCrZr; Ø 1.6 (10x30)	10 Pcs.	140.0590	1031
90	Contact tip M8 E-Cu; Ø 0.8 for alu wire (10x30)	10 Pcs.	141.0003	1030
90	Contact tip M8 E-Cu; Ø 1.0 for alu wire (10x30)	10 Pcs.	141.0008	1030
90	Contact tip M8 E-Cu; Ø 1.2 for alu wire (10x30)	10 Pcs.	141.0015	1030
90	Contact tip M8 E-Cu; Ø 1.4 for alu wire (10x30)	10 Pcs.	141.0055	1030
90	Contact tip M8 E-Cu; Ø 1.6 for alu wire (10x30)	10 Pcs.	141.0022	1030
90	Contact tip M8 CuCrZr silver-plated; Ø 0.8 (10x30)	10 Pcs.	147.0117	1031
90	Contact tip M8 CuCrZr silver-plated; Ø 1.0 (10x30)	10 Pcs.	147.0316	1031
90	Contact tip M8 CuCrZr silver-plated; Ø 1.2 (10x30)	10 Pcs.	147.0445	1031
90	Contact tip M8 CuCrZr silver-plated; Ø 1.4 (10x30)	10 Pcs.	147.0536	1031
90	Contact tip M8 CuCrZr silver-plated; Ø 1.6 (10x30)	10 Pcs.	147.0590	1031
90	Contact tip M8 HDS silver-plated; Ø 1.0 (10x30)	10 Pcs.	147.5316	5038
90	Contact tip M8 HDS silver-plated; Ø 1.2 (10x30)	10 Pcs.	147.5445	5038
90	Contact tip M8 HDS silver-plated; Ø 1.4 (10x30)	10 Pcs.	147.5536	5038
90	Contact tip M8 HDS silver-plated; Ø 1.6 (10x30)	10 Pcs.	147.5590	5038
100	Gas nozzle M16; ND 18; galvanized; conical L=72 mm	5 Pcs.	145.D021	1537
100	Gas nozzle M16; ND 18 blank; with extended insulation	5 Pcs.	145.D194	1537
	Gas nozzle M16; ND 16 galvanized; conical L=69 mm	5 Pcs.	145.D022	1537
	Gas nozzle M16; NW 14; galvanized; conical L=69 mm	5 Pcs.	145.D023	1537
	Gas nozzle M16; NW 18; galvanized; conical L=72 mm	5 Pcs.	145.D036	1537
	Gas nozzle M16; NW 16; galvanized; conical L=72 mm	5 Pcs.	145.D026	1537
	Gas nozzle M16; ND 15 blank; with extended insulation	5 Pcs.	145.D217	1537
	Gas nozzle M16; NW 12; galvanized; conical L=72 mm	5 Pcs.	145.D025	1537
	Gas nozzle M16; NW 10; galvanized; conical L=69 mm	5 Pcs.	145.D267	1537
102	Gas nozzle M16; ND 21 galvanized; cylindrical	5 Pcs.	145.D024	1537
102	Gas nozzle M16; NW 21; galvanized; cylindrical L=72 mm; with extended insulation	5 Pcs.	145.D353	1537

MIG/MAG Welding Torches ABIMIG® A T 305 LW

Pos.	Description	Units	Part-No.	Product-group
103	Gas nozzle (slip-on) D15; ND 16 galvanized	5 Pcs.	145.D378.5	1537
	Gas nozzle pluggable D17; NW 13; galvanized; conical L=72 mm; with extended insulation	5 Pcs.	145.D438.5	1537
	Gas nozzle pluggable D17; NW 18; galvanized; conical L=72 mm; with extended insulation	5 Pcs.	145.D439.5	1537
104	Spot weld gas nozzle M16; NW 21; galvanized; L=91 mm		145.D028	1537
110	Neck liner 1.5; for wire Ø 0.6-1.0; for ABIMIG® T-Line		122.D037	1534
110	Neck liner 2.0; for wire Ø 1.0-1.2; for ABIMIG® T-Line		122.D038	1534
110	Neck liner 2.5; for wire Ø 1.2-1.4; for ABIMIG® T-Line		122.D039	1534
110	Neck liner 1.6; brass; for wire Ø 0.6-1.0; for ABIMIG® T-Line		122.D040	1534
110	Neck liner 2.2; brass; for wire Ø 1.0-1.4; for ABIMIG® T-Line		122.D041	1534
120	Guide spiral liner insulated; 1.5/4.5; blue; for wire Ø 0.6-0.8; for 3.00 m		124.0011	1034
120	Guide spiral liner insulated; 1.5/4.5; blue; for wire Ø 0.6-0.8; for 4.00 m		124.0012	1034
120	Guide spiral liner insulated; 1.5/4.5; blue; for wire Ø 0.6-0.8; for 5.00 m		124.0015	1034
120	Guide spiral liner insulated; 1.5/4.5; blue; wire-Ø 0.6-0.8; for 6.00 m		124.0016	1034
120	Guide spiral liner insulated; 2.0/4.5; red; for wire Ø 1.0-1.2; for 3.00 m		124.0026	1034
120	Guide spiral liner insulated; 2.0/4.5; red; for wire Ø 1.0-1.2; for 4.00 m		124.0031	1034
120	Guide spiral liner insulated; 2.0/4.5; red; for wire Ø 1.0-1.2; for 5.00 m		124.0035	1034
120	Guide spiral liner insulated; 2.0/4.5; red; wire-Ø 1.0-1.2; for 6.00 m		124.0036	1034
120	Guide spiral liner insulated; 2.5/4.5; yellow; for wire Ø 1.4-1.6; for 3.00 m		124.0041	1034
120	Guide spiral liner insulated; 2.5/4.5; yellow; for wire Ø 1.4-1.6; for 4.00 m		124.0042	1034
120	Guide spiral liner insulated; 2.5/4.5; yellow; for wire Ø 1.4-1.6; for 5.00 m		124.0044	1034
120	Guide spiral liner insulated; 2.5/4.5; yellow; wire Ø 1.4-1.6; for 6.00 m		124.0045	1034
130	PTFE core liner 1.5/4.0; blue; wire electrode Ø 0.8-1.0; for 3.00 m		126.0005	1034
130	PTFE core liner 1.5/4.0; blue; wire electrode Ø 0.8-1.0; for 4.00 m		126.0008	1034
130	PTFE core liner 1.5/4.0; blue; wire electrode Ø 0.8-1.0; for 5.00 m		126.0011	1034
130	PTFE core liner 1.5/4.0; blue; wire electrode Ø 0.6-1.0; for 8.00 m		126.0013	1034
130	PTFE core liner 2.0/4.0; red; wire electrode Ø 1.0-1.2; for 3.00 m		126.0021	1034
130	PTFE core liner 2.0/4.0; red; wire electrode Ø 1.0-1.2; for 4.00 m		126.0026	1034
130	PTFE core liner 2.0/4.0; red; wire electrode Ø 1.0-1.2; for 5.00 m		126.0028	1034
130	PTFE core liner 2.0/4.0; red; wire electrode Ø 0.8-1.2; for 8.00 m		126.0030	1034
130	PTFE carbon core liner 1.5/4.0; wire electrode Ø 0.8-1.0; for 3.00 m		127.0002	1034
130	PTFE carbon core liner 1.5/4.0; wire electrode Ø 0.8-1.0; for 4.00 m		127.0003	1034
130	PTFE carbon core liner 1.5/4.0; wire electrode Ø 0.8-1.0; for 5.00 m		127.0004	1034
130	PTFE carbon core liner 1.5/4.0; wire electrode Ø 0.6-1.0; for 8.00 m		127.0015	1034
130	PTFE carbon core liner 2.0/4.0; wire electrode Ø 1.0-1.2; for 3.00 m		127.0005	1034
130	PTFE carbon core liner 2.0/4.0; wire electrode Ø 1.0-1.2; for 4.00 m		127.0007	1034
130	PTFE carbon core liner 2.0/4.0; wire electrode Ø 1.0-1.2; for 5.00 m		127.0008	1034
130	PTFE carbon core liner 2.0/4.0; wire electrode Ø 0.8-1.2; for 8.00 m		127.0009	1034
131	Nipple for core liner at Ø 4.0	20 Pcs.	131.0001	1095
132	O-Ring 3.5x1.5	20 Pcs.	165.0008	9010
133	Guide tube for core liners up to Ø 4.0 (200 mm)	10 Pcs.	129.0461	1095
200	Spanner for ABIMIG®		191.D045	1595

MIG/MAG Welding Torches ABIMIG® A T 405 LW

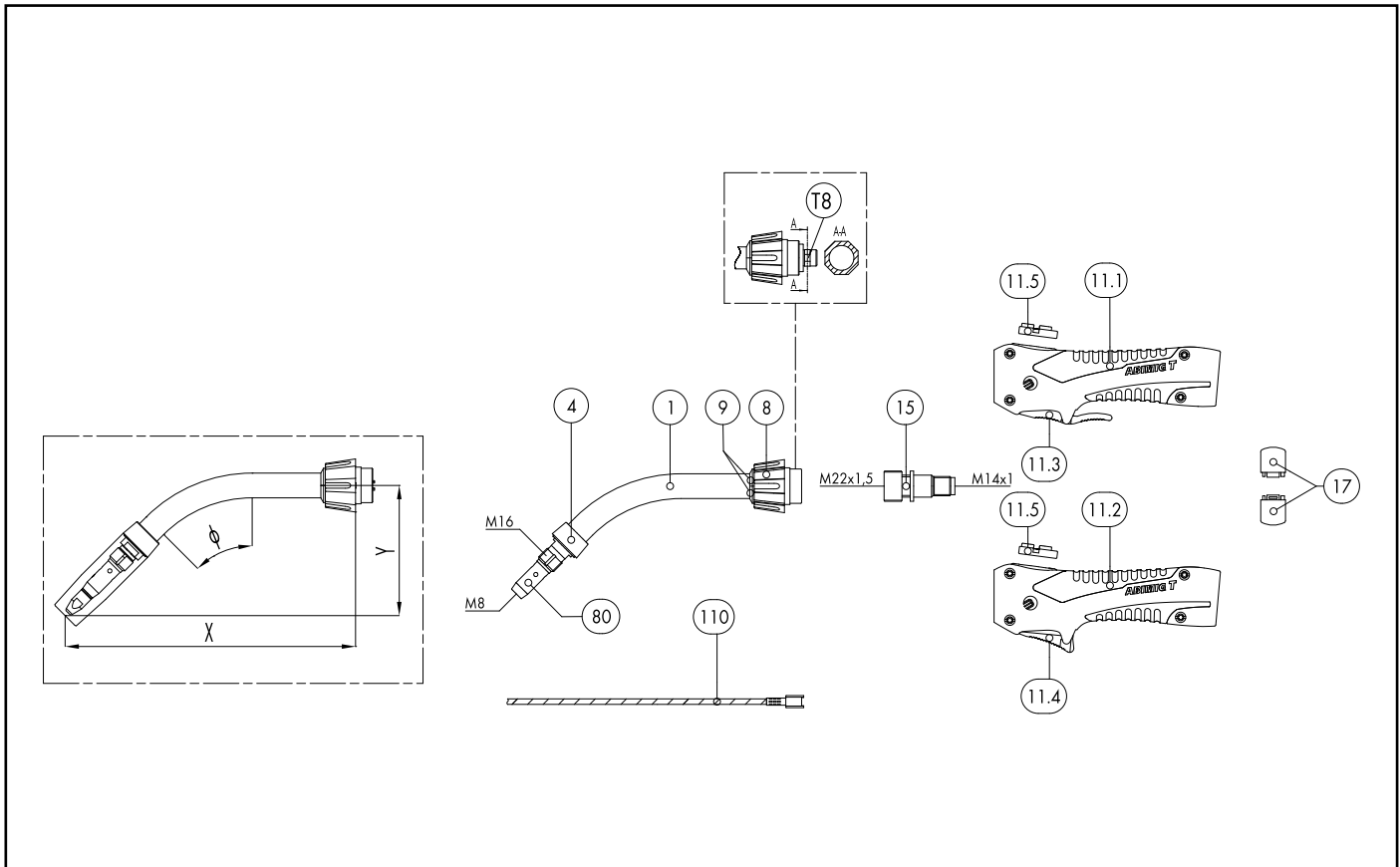

Pos.	Description	Units	Part-No.	Product-group
Basic torch (complete)				
	ABIMIG® A T 405 LW; T8M45°; central adaptor KZ-2; 3.00 m		015.D070.1	1324
	ABIMIG® A T 405 LW; T8M45°; central adaptor KZ-2; 4.00 m		015.D071.1	1324
	ABIMIG® A T 405 LW; T8M45°; central adaptor KZ-2; 5.00 m		015.D072.1	1324
Combi torch (basic torch without neck and wear parts)				
	ABIMIG® A T G 405 LW; central adaptor KZ-2; 3.00 m		015.D114.1	1326
	ABIMIG® A T G 405 LW; central adaptor KZ-2; 4.00 m		015.D115.1	1326
	ABIMIG® A T G 405 LW; central adaptor KZ-2; 5.00 m		015.D116.1	1326
Swan neck				
1	Swan neck ABIMIG® A 405 LW; 45° bent		015.D082.1	1308
1	Swan neck ABIMIG® A T 405K T8M; 45°; X=185; Y=95; gas nozzle screwed		015.D117.1	1308
	Swan neck ABIMIG® A T 407 T8M; 45°; X=210; Y=95; gas nozzle mated		015.D089.1	1308
	Swan neck ABIMIG® A T 405K T8M; 45°; X=195; Y=95; gas nozzle mated		015.D123.1	1308
	COMBI swan neck A T 405 K T8M cpl.; 45°; X=185; Y=95; gas nozzle screwed		015.0088.1	1308
	COMBI swan neck A T 405 T8M cpl.; 45°; X=210; Y=95; gas nozzle screwed		015.0089.1	1308
4	Head insulation	5 Pcs.	015.D080.5	1595
4	Spacer	5 Pcs.	015.D081.5	1595
8	Coupling nut M22x1.5		014.H279.1	1595
9	Protective cab (split) D=18 for round-neck nut	10 Pcs.	014.H283.10	1595
Handle				
11.1	Handle ABIMIG® A T with push-button long		180.D077.1	1595
11.1	Handle ABIMIG® A T with push-button long (without module BIS-52)		180.D079.1	1595
11.2	Handle ABIMIG® A T with push-button short		180.D078.1	1595
11.2	Handle ABIMIG® A T with push-button short (without module BIS-52)		180.D080.1	1595
11.3	Trigger long 2-pole		185.D118.1	1595
11.4	Trigger short 2-pole		185.D120.1	1595

MIG/MAG Welding Torches ABIMIG® A T 405 LW

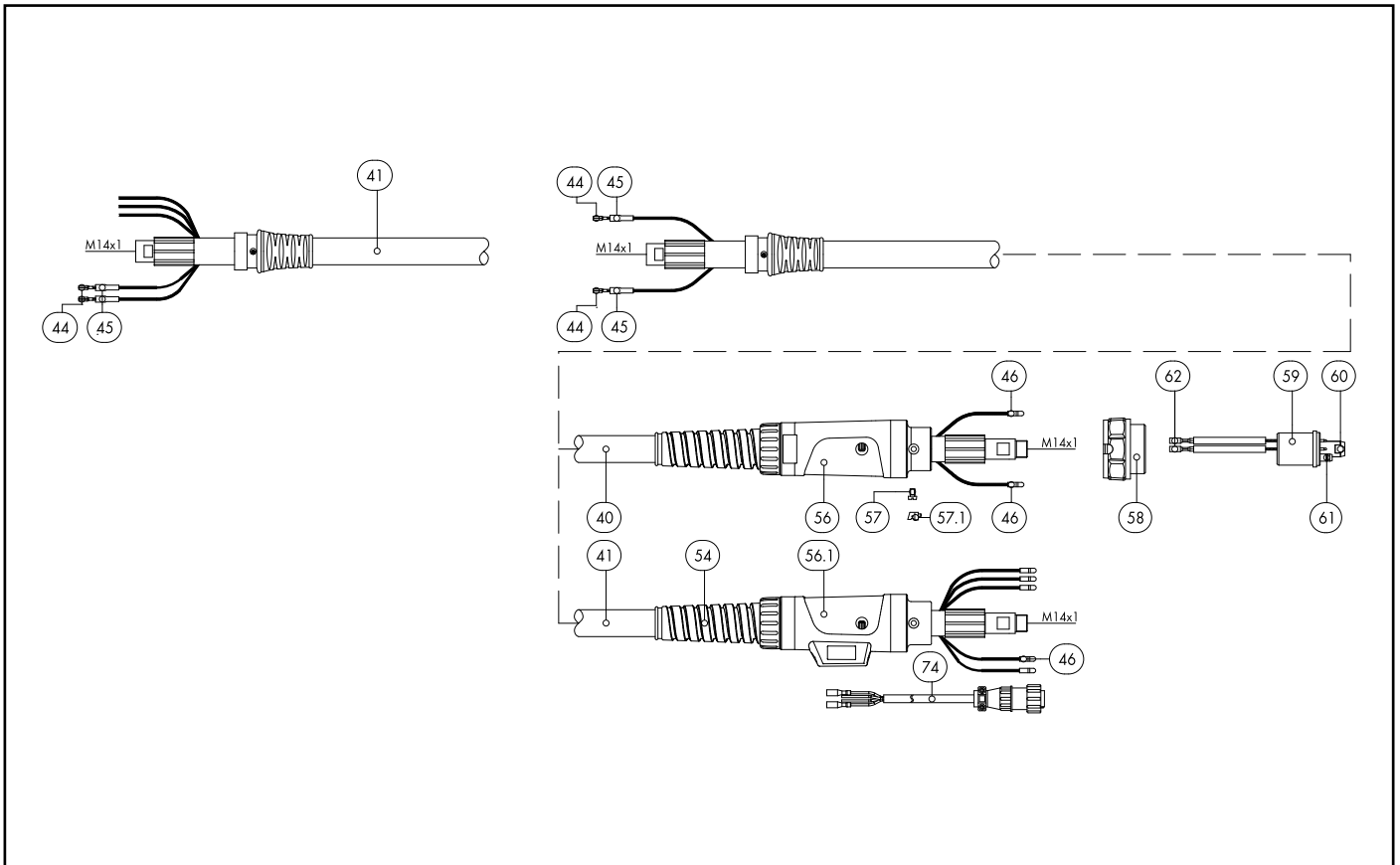

Pos.	Description	Units	Part-No.	Product-group
11.5	Blind cover		400.D573.1	1595
15	Torch pipe connection M22x1.5 / M14x1		016.D392.1	1595
17	Half rings (1 pair)	2 Pcs.	400.D561.2	1595
Cable assembly				
40	Bikox® LW power cable, R9 for 3.00 m		160.H344.1	1511
40	Bikox® LW power cable, R9 for 4.00 m		160.H345.1	1511
40	Bikox® LW cable assembly; R9 2-pole for 4.50 m		160.H377.1	1511
40	Bikox® LW power cable, R9 for 5.00 m		160.H346.1	1511
40	Bikox® LW cable assembly; R9 2-pole for 4.50 m		160.H442.1	1511
40	Bikox® LW cable assembly, R9 5-pole Up/Down for 3.00 m		160.H347.1	1511
40	Bikox® LW cable assembly, R9 5-pole Up/Down for 4.00 m		160.H348.1	1511
40	Bikox® LW cable assembly, R9 5-pole Up/Down for 4.50 m		160.H443.1	1511
40	Bikox® LW cable assembly, R9 5-pole Up/Down for 5.00 m		160.H349.1	1511
40	Bikox® LW cable assembly, R9 5-pole Up/Down for 6.00 m		160.H444.1	1511
44	Trigger wire connector	20 Pcs.	175.0022	9010
45	Insulating sleeve	20 Pcs.	400.0119	1095
46	Plug	20 Pcs.	175.0004	9010
54	Cable support NW 21		400.D518.1	1595
54.1	Cable support ABIMIG® A T LW (short)		400.D574.1	1595
54.1	Cable support NW 21		400.D518.1	1595
54.1	Cable support spring NW 22		400.D501.1	1595
56	Cable support machine side		501.2248	9010
56.1	Connection housing machine side cpl.; for UNI-plug		501.D578.1	1595
57	Pan head screw M4x6	20 Pcs.	000.0552	9010
57.1	Screw cap 1	20 Pcs.	500.0251	9010
58	Adaptor nut M33x2		500.0213	9010

MIG/MAG Welding Torches ABIMIG® A T 405 LW

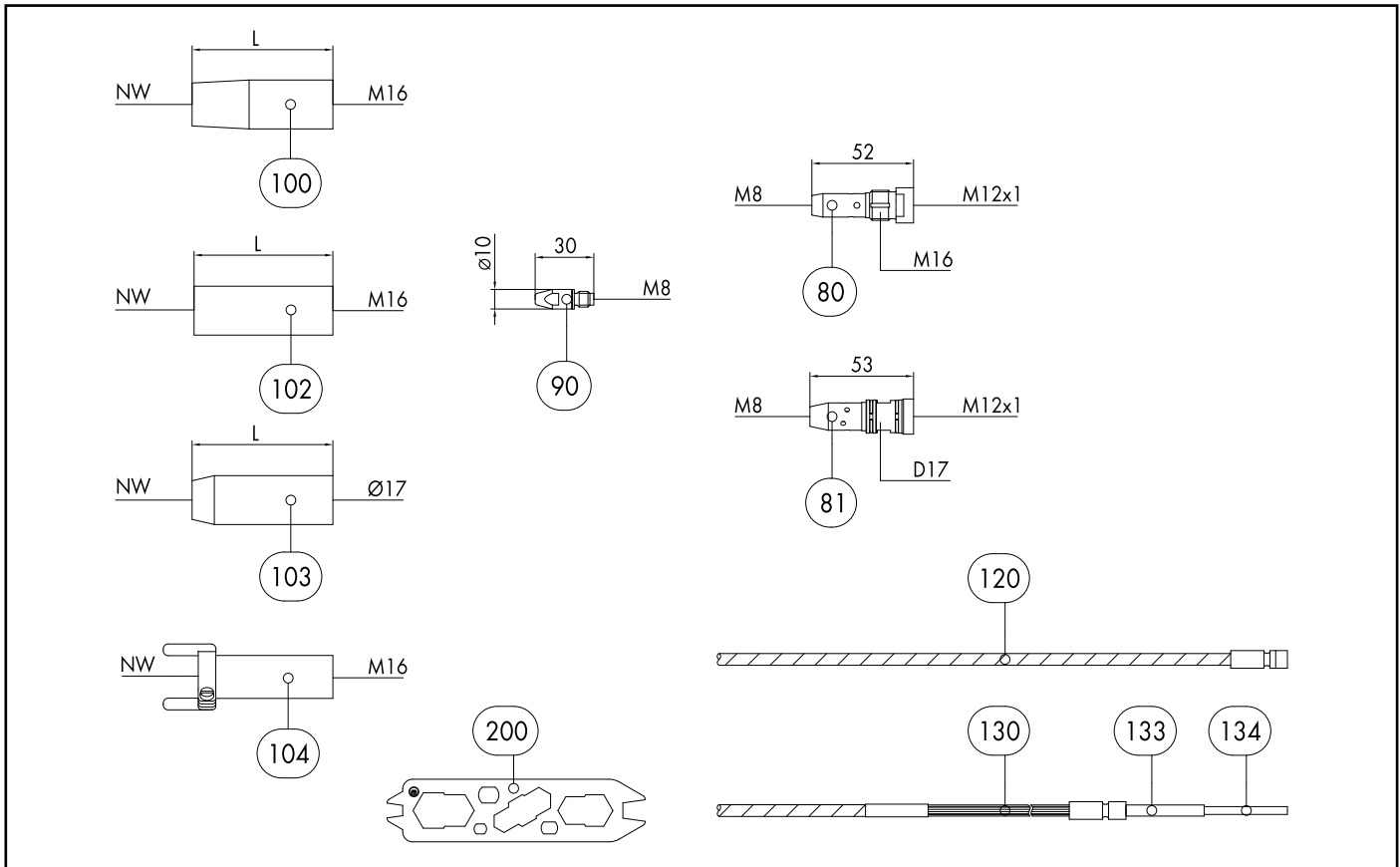

Pos.	Description	Units	Part-No.	Product-group
59	Central adaptor KZ-2		501.D687.1	1595
60	Coupling nut M14x1, plastic	5 Pcs.	501.D537.5	1595
61	O-Ring 4x1	20 Pcs.	165.0002	9010
62	Trigger wire connector; female	20 Pcs.	175.0003	9010
74	Control cable with 4-pole Amphenol plug L=400 mm		175.D098	1595
74.1	Protective tube 4.5x0.5, L=60 mm		110.D023	1595
Wear parts				
80	Contact tip holder M16/M8/52 US	5 Pcs.	014.D745.5	1533
81	Contact tip holder D17/M8/53 for slip-on gas nozzle	5 Pcs.	014.H129.5	1533
	Contact tip holder D17/M8/51 cpl.; for pluggable gas nozzle XX7	5 Pcs.	014.H194.5	1533
90	Contact tip M8 E-Cu; Ø 1.0 (10x30)	10 Pcs.	140.0313	1030
90	Contact tip M8 E-Cu; Ø 1.2 (10x30)	10 Pcs.	140.0442	1030
90	Contact tip M8 E-Cu; Ø 1.4 (10x30)	10 Pcs.	140.0533	1030
90	Contact tip M8 E-Cu; Ø 1.6 (10x30)	10 Pcs.	140.0587	1030
90	Contact tip M8 E-Cu; Ø 2.0 (10x30)	10 Pcs.	140.0653	1030
90	Contact tip M8 E-Cu; Ø 2.4 (10x30)	10 Pcs.	140.0677	1030
90	Contact tip M8 CuCrZr; Ø 1.0 (10x30)	10 Pcs.	140.0316	1031
90	Contact tip M8 CuCrZr; Ø 1.2 (10x30)	10 Pcs.	140.0445	1031
90	Contact tip M8 CuCrZr; Ø 1.4 (10x30)	10 Pcs.	140.0536	1031
90	Contact tip M8 CuCrZr; Ø 1.6 (10x30)	10 Pcs.	140.0590	1031
90	Contact tip M8 CuCrZr; Ø 2.0 (10x30)	10 Pcs.	140.0656	1031
90	Contact tip M8 CuCrZr; Ø 2.4 (10x30)	10 Pcs.	140.0679	1031
90	Contact tip M8 E-Cu; Ø 1.0 for alu wire (10x30)	10 Pcs.	141.0008	1030
90	Contact tip M8 E-Cu; Ø 1.2 for alu wire (10x30)	10 Pcs.	141.0015	1030
90	Contact tip M8 E-Cu; Ø 1.4 for alu wire (10x30)	10 Pcs.	141.0055	1030
90	Contact tip M8 E-Cu; Ø 1.6 for alu wire (10x30)	10 Pcs.	141.0022	1030

MIG/MAG Welding Torches ABIMIG® A T 405 LW

Pos.	Description	Units	Part-No.	Product-group
90	Contact tip M8 E-Cu; Ø 2.0 for alu wire (10x30)	10 Pcs.	141.0033	1030
90	Contact tip M8 E-Cu; Ø 2.4 for alu wire (10x30)	10 Pcs.	141.0035	1030
90	Contact tip M8 CuCrZr silver-plated; Ø 1.0 (10x30)	10 Pcs.	147.0316	1031
90	Contact tip M8 CuCrZr silver-plated; Ø 1.2 (10x30)	10 Pcs.	147.0445	1031
90	Contact tip M8 CuCrZr silver-plated; Ø 1.4 (10x30)	10 Pcs.	147.0536	1031
90	Contact tip M8 CuCrZr silver-plated; Ø 1.6 (10x30)	10 Pcs.	147.0590	1031
90	Contact tip M8 CuCrZr silver-plated; Ø 2.0 (10x30)	10 Pcs.	147.0656	1031
90	Contact tip M8 CuCrZr silver-plated; Ø 2.4 (10x30)	10 Pcs.	147.0679	1031
90	Contact tip M8 HDS silver-plated; Ø 1.0 (10x30)	10 Pcs.	147.5316	5038
90	Contact tip M8 HDS silver-plated; Ø 1.2 (10x30)	10 Pcs.	147.5445	5038
90	Contact tip M8 HDS silver-plated; Ø 1.4 (10x30)	10 Pcs.	147.5536	5038
90	Contact tip M8 HDS silver-plated; Ø 1.6 (10x30)	10 Pcs.	147.5590	5038
100	Gas nozzle M16; ND 18; galvanized; conical L=72 mm	5 Pcs.	145.D021	1537
100	Gas nozzle M16; ND 18 blank; with extended insulation	5 Pcs.	145.D194	1537
	Gas nozzle M16; ND 16 galvanized; conical L=69 mm	5 Pcs.	145.D022	1537
	Gas nozzle M16; NW 14; galvanized; conical L=69 mm	5 Pcs.	145.D023	1537
	Gas nozzle M16; NW 16; galvanized; conical L=72 mm	5 Pcs.	145.D026	1537
	Gas nozzle M16; NW 18; galvanized; conical L=72 mm	5 Pcs.	145.D036	1537
	Gas nozzle M16; ND 15 blank; with extended insulation	5 Pcs.	145.D217	1537
	Gas nozzle M16; NW 12; galvanized; conical L=72 mm	5 Pcs.	145.D025	1537
	Gas nozzle M16; NW 10; galvanized; conical L=69 mm	5 Pcs.	145.D267	1537
102	Gas nozzle M16; ND 21 galvanized; cylindrical	5 Pcs.	145.D024	1537
102	Gas nozzle M16; NW 21; galvanized; cylindrical L=72 mm; with extended insulation	5 Pcs.	145.D353	1537
103	Gas nozzle (slip-on) D15; ND 16 galvanized	5 Pcs.	145.D378.5	1537
103	Gas nozzle pluggable D17; NW 18; galvanized; conical L=72 mm; with extended insulation	5 Pcs.	145.D439.5	1537
103	Gas nozzle pluggable D17; NW 13; galvanized; conical L=72 mm; with extended insulation	5 Pcs.	145.D438.5	1537
104	Spot weld gas nozzle M16; NW 21; galvanized; L=91 mm		145.D028	1537
110	Neck liner 1.9; for wire Ø 1.0-1.2; for ABIMIG® T-Line		122.D077	1534
110	Neck liner 2.2; for wire Ø 1.4-1.6; for ABIMIG® T-Line		122.D078	1534
120	Guide spiral liner insulated; 1.9/5.5; red; for wire Ø 1.0-1.2; for 3.00 m		124.D113	1534
120	Guide spiral liner insulated; 1.9/5.5; red; for wire Ø 1.0-1.2; for 4.00 m		124.D114	1534
120	Guide spiral liner insulated; 1.9/5.5; red; for wire Ø 1.0-1.2; for 5.00 m		124.D115	1534
120	Guide spiral liner insulated; 2.0/5.5; red; wire Ø 1.0-1.2; for 6.00 m		124.D156.1	1534
120	Guide spiral liner insulated; 2.2/6.0; white; for wire Ø 1.4-1.6; for 3.00 m		124.D116	1534
120	Guide spiral liner insulated; 2.2/6.0; white; for wire Ø 1.4-1.6; for 4.00 m		124.D117	1534
120	Guide spiral liner insulated; 2.2/6.0; white; for wire Ø 1.4-1.6; for 5.00 m		124.D118	1534
120	Guide spiral liner insulated; 2.2/6.0; white; wire Ø 1.4-1.6; for 6.00 m		124.D144.1	1534
120	Guide spiral liner insulated; 3.0/6.4; blue; for wire Ø 2.0-2.4; for 3.00 m		124.D119	1534
120	Guide spiral liner insulated; 3.0/6.4; blue; for wire Ø 2.0-2.4; for 4.00 m		124.D120	1534
120	Guide spiral liner insulated; 3.0/6.4; blue; for wire Ø 2.0-2.4; for 5.00 m		124.D121	1534
120	Guide spiral liner insulated; 3.0/6.4; blue; wire Ø 2.0-2.4; for 6.00 m		124.D157.1	1534
130	Combined wire guide cpl.P; wire Ø 1.0; for 3.00 m		126.D026.1	1534
130	Combined wire guide cpl.P; wire Ø 1.0; for 4.00 m		126.D027.1	1534
130	Combined wire guide cpl.P; wire Ø 1.0; for 5.00 m		126.D028.1	1534
130	Combined wire guide P; wire-Ø 1.0-1.2; řřr 6.00 m		126.D058.1	1534
130	Combined wire guide cpl.P; wire Ø 1.2-1.4; for 3.00 m		126.D029.1	1534
130	Combined wire guide cpl.P; wire Ø 1.2-1.4; for 4.00 m		126.D030.1	1534
130	Combined wire guide cpl.P; wire Ø 1.2-1.4; for 5.00 m		126.D031.1	1534
130	Combined wire guide cpl.P; wire Ø 1.0; for 4.00 m		126.D027.1	1534
133	Guide tube for core liners up to Ø 4.0 (200 mm)	10 Pcs.	129.0461	1095

