

ORBIWELD 38S, 115S

Closed orbital weld heads

Handier, more efficient, effective - closed TIG orbital weld head with outstanding specifications: The ORBIWELD "S" series from Orbitalum convinces by its extremely narrow design and highly resilient through efficient liquidcooling.



Thanks to its compact dimensions, the ORBIWELD "S" series is ideal for applications, under tight spaces as they often occur in the pharmaceuticals, chemical, semiconductor and food processing industry as well as in aerospace technology.

All closed weld heads of the ORBIWELD series are manufactured from outstanding materials and characterized by a unique cooling system. The fitting clamping inserts are designed to be of high-quality, functional and durable and do not wear as rapidly as those of many of the competitors. The clamping inserts are available in small (narrow) and wide versions and can be inserted into the weld head rapidly and easily.

FURTHER PROPERTIES:

- Thanks to the extremely narrow design, parts with short welding lengths can also be processed
- High quality, robust housing and handles
- Highly resilient through completely liquid-cooled weld head housing
- Highly flexible hose package (length: 7.5 m/24.6 ft) with strain relief to the power source
- With a control panel integrated in the robust and stable aluminum handle of the weld head, all commands which are important for the welding can be transferred to the power source so that no additional remote control is required
- Quick change system for clamping inserts allows simple locking and releasing without tools

- Cost-effective clamping inserts
- Stable clamping locks in connection with the clamping inserts available for all tube dimensions ensure a secure and offset-free clamping and centering of the parts to be welded
- Comprehensive and customer-specific accessories program
- A folding cover at the weld head - allows checking and, if necessary, readjustment of the electrode position before welding

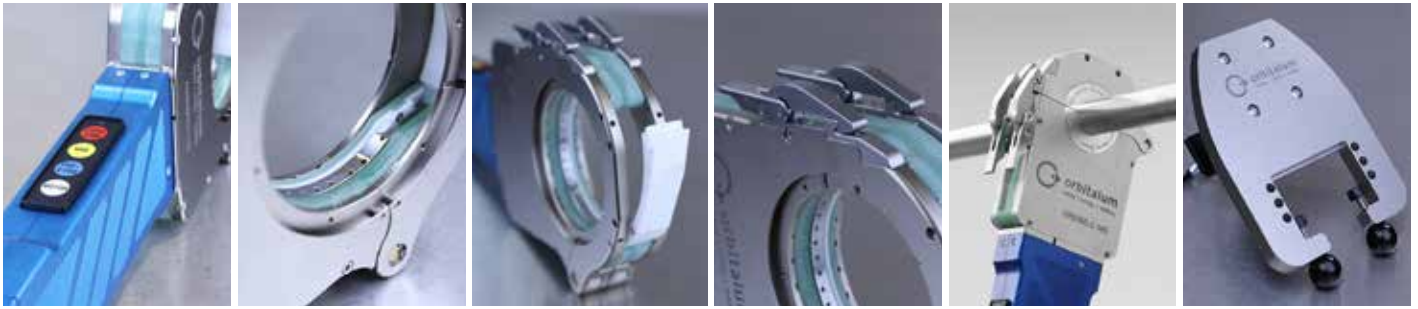

Robust and stable aluminum handle with integrated control panel

Simpler inserting of the electrodes by markings for \varnothing 1.6/2.4 mm (0.063"/0.094")

Flip-up weld head cover "FlipCover"

Stable clamping locks

Diameter-specific aluminum clamping inserts (each of 2 half-shells) available separately

Wide accessories program, e.g. table mounts

DIMENSIONS	ORBIWELD 38S				ORBIWELD 115S					
	DIMENSION		ELECTRODE GAP CLAMPING INSERT*		DIMENSION		ELECTRODE GAP			
	[MM]	[INCH]	[MM]	[INCH]	[MM]	[INCH]	CLAMPING INSERT* TYPE "S"		CLAMPING INSERT+ TYPE "W"	
	[MM]	[INCH]	[MM]	[INCH]	[MM]	[INCH]	[MM]	[INCH]	[MM]	[INCH]
Dimension "A1"	17.00	0.669	17.50	0.689	22.75	0.896	25.00	0.984	45.75	1.801
Dimension "A2"	17.00	0.669	17.50	0.689	21.25	0.837	25.00	0.984	44.25	1.742
Dimension "B"	34.00	1.339	35.00	1.378	44.00	1.732	50.00	1.969	90.00	3.543
Dimension "C"	112.00	4.409			220.00	8.661				
Dimension "D"	47.50	1.870			104.00	4.094				
Dimension "E"	47.00	1.850			102.00	4.016				
Dimension "F"	144.00	5.669			244.00	9.606				
Dimension "G"	357.00	14.055			480.00	18.898				
Dimension "H"	95.00	3.740			208.00	8.189				
Dimension "I"	34.00	1.339			44.00	1.732				
Dimension "J"	55.00	2.165			55.00	2.165				
Dimension "K"	71.00	2.795			102.00	4.016				
Dimension "L"	110.00	4.331			216.00	8.504				

* 2 pairs

APPLICATION AREA	ORBIWELD 38S	ORBIWELD 115S
Code	826 000 001	828 000 001
Tube OD, min. - max.	3 - 38.1 mm 1/8" - 1.5"	20 - 115 mm 3/4" - 4.5"
Electrode diameter	1.6/2.4 mm .063"/.094"	1.6/2.4 mm .063"/.094"
Machine weight including hose package	6.9 kg 15.2 lbs	9.7 kg 21.4 lbs
Hose package length	7.5 m/24.6 ft	7.5 m/24.6 ft

SCOPE OF DELIVERY

Including:	<ul style="list-style-type: none"> • 1 orbital weld head OW 38S or OW 115S • 1 transport case • 1 tool set • 1 feeler gauge • 1 operating instructions and spare parts list • General safety instructions
Suitable accessories (optionally available):	<ul style="list-style-type: none"> • Clamping inserts, narrow and wide • Chamber insert for fittings • Inserts for arc welding • T-piece clamping inserts • Electrode adapters • Table mounts • ESG electrode grinders • ORBmax residual oxygen meter • ORBIPURGE forming set • Hose package extensions • WS2 tungsten electrodes

Technical specifications are non-binding. They do not constitute any assurance of properties. We reserve the right to make changes.

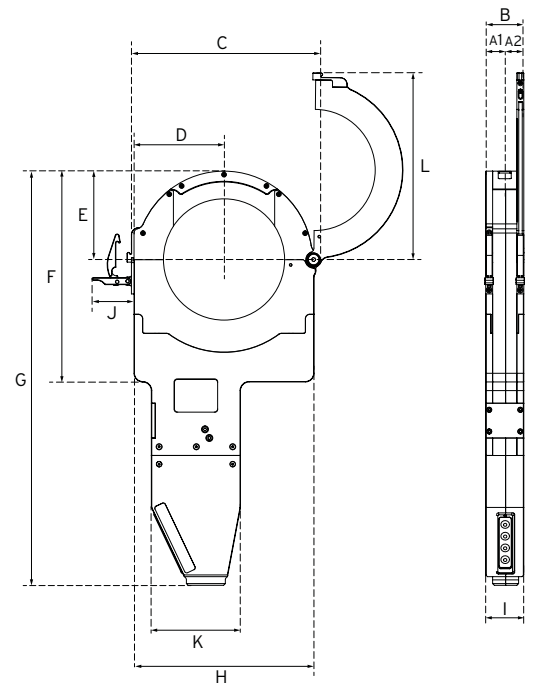

ORBIWELD 38S

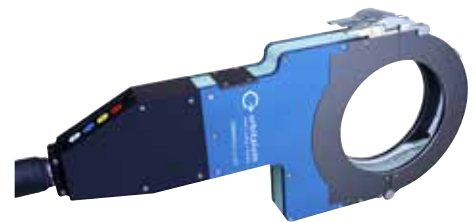

ORBIWELD 115S

Closed orbital weld heads OW S

ORBIWELD 38S, ORBIWELD 115S

Properties, application area, technical specifications and delivery scope, see page 52.

Clamping inserts are not included in the scope of delivery (see from page 63).



ORBIWELD 38S

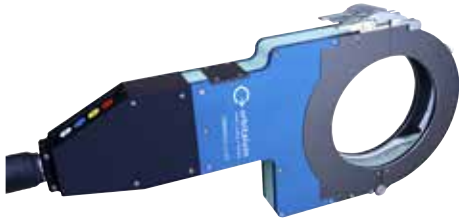

ORBIWELD 115S

ITEM	CODE	MACHINE WEIGHT KG*	SHIPPING WEIGHT KG
Orbital weld head OW 38S	826 000 001	6.900	16.500
Orbital weld head OW 115S	828 000 001	9.700	18.600

* Machine weight including hose package

Suitable accessories (optionally available):

- Clamping inserts for ORBIWELD S and ORBIWELD
- Chamber inserts for fittings
- Inserts for arc welding
- T-piece clamping inserts
- Electrode adapters
- Table mounts
- Welding current connection adapter set