

Robacta 400

(D) Ersatzteilliste
MIG/MAG-Roboter-Rohrbogen

(GB) Spare Parts List
MIG/MAG Robot torch body

(F) Liste de pièces de rechange
corps de chalumeau robot
MIG/MAG

(I) Lista parti di ricambio
curva robot MIG/MA

(E) Lista de repuestos
Codo de tubo para robot
MIG/MAG

(P) Lista de peças sobresselentes
Queimador de soldadura robot
MIG/MAG

44,0350,2435	Robacta 400 0°
44,0350,2435,630	Robacta 400 0° OVT
44,0350,2436	Robacta 400 22°
44,0350,2436,630	Robacta 400 22° OVT
34,0350,1908	Robacta 400 36°
34,0350,1908,630	Robacta 400 36° OVT
44,0350,2437	Robacta 400 45°
44,0350,2437,630	Robacta 400 45° OVT



Robacta 400

Ersatzteilliste / Spare parts list / Listes de pièces de rechange / Lista de repuestos / Lista de peças sobresselentes / Lista dei Ricambi

ROBACTA 400 36° M8

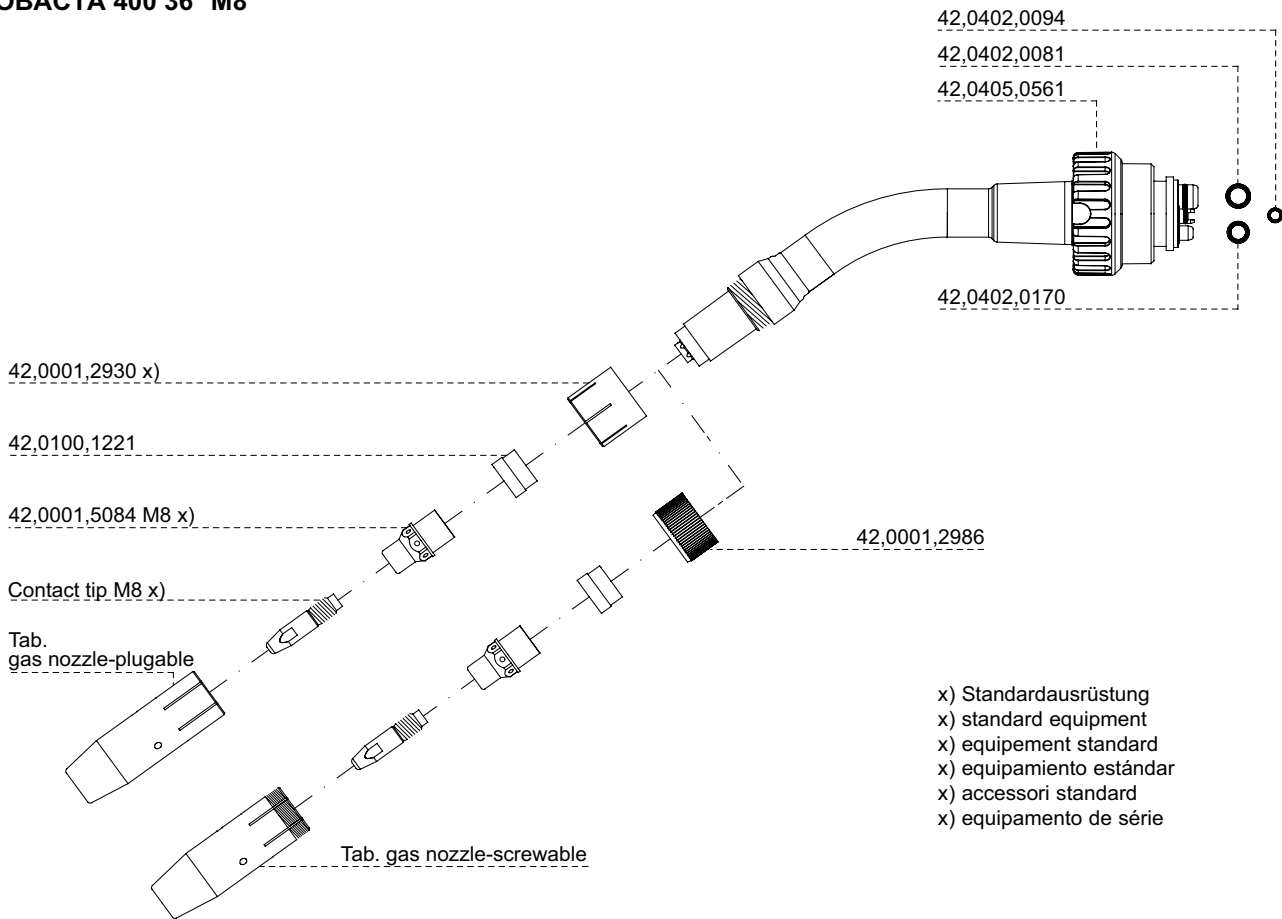

- x) Standardausrüstung
- x) standard equipment
- x) équipement standard
- x) equipamiento estándar
- x) accessori standard
- x) equipamento de série

ROBACTA 400 36° M6

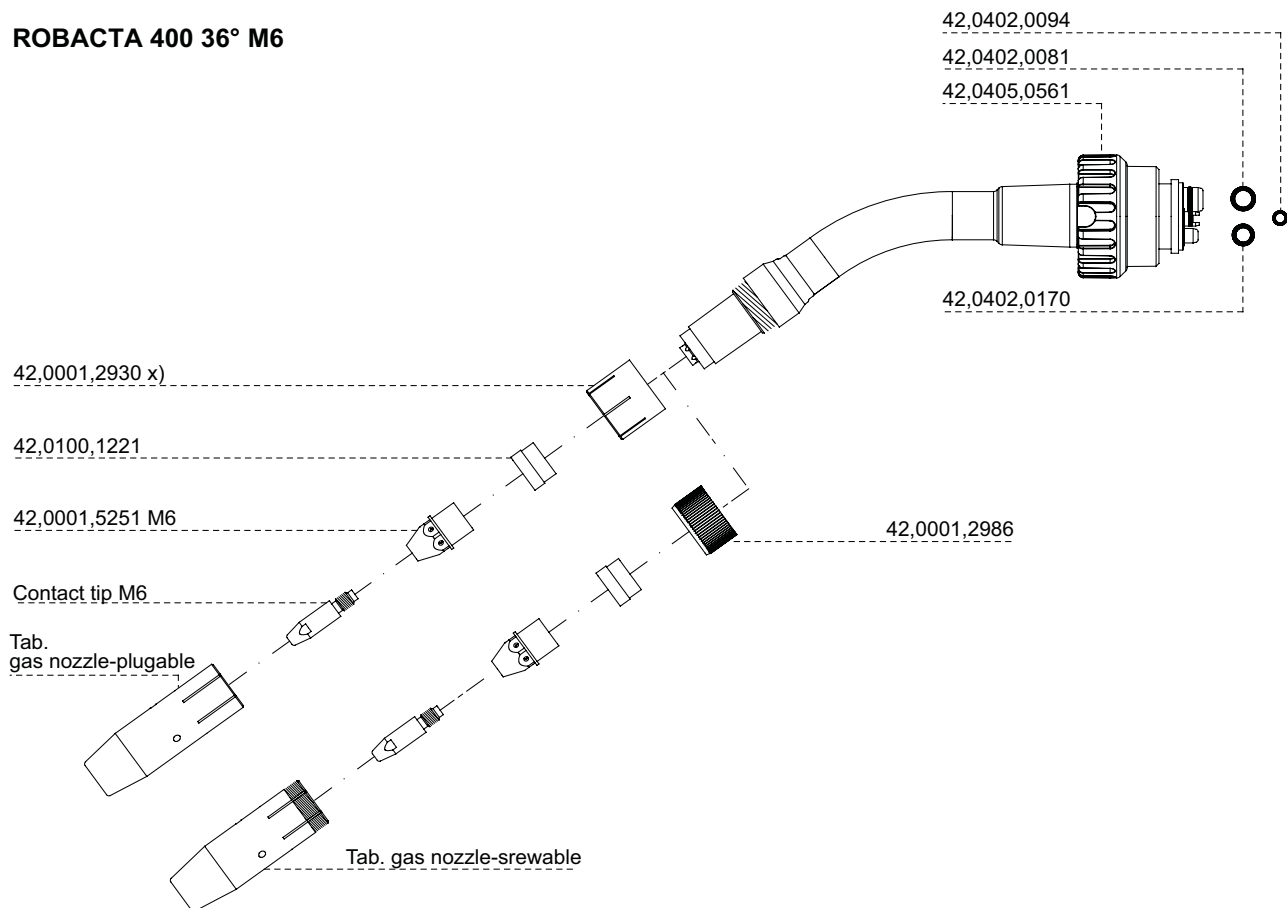

Robacta 400

Ersatzteilliste / Spare parts list / Listes de pièces de rechange / Lista de repuestos / Lista de peças sobresselentes / Lista dei Ricambi

ROBACTA 400 - Standard

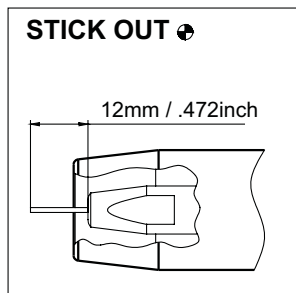
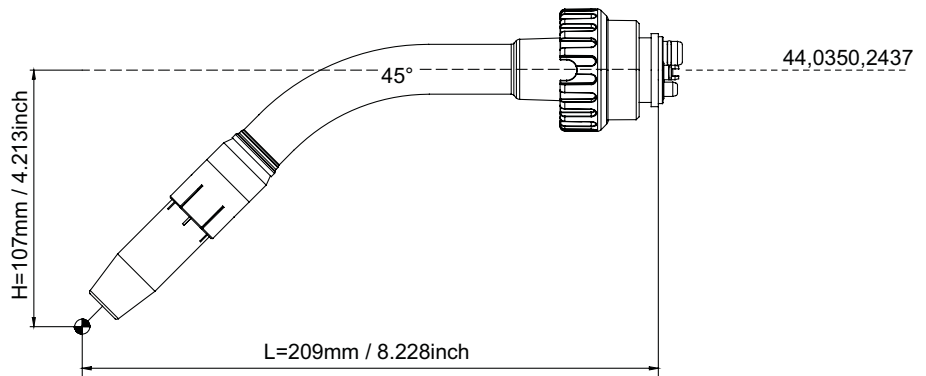
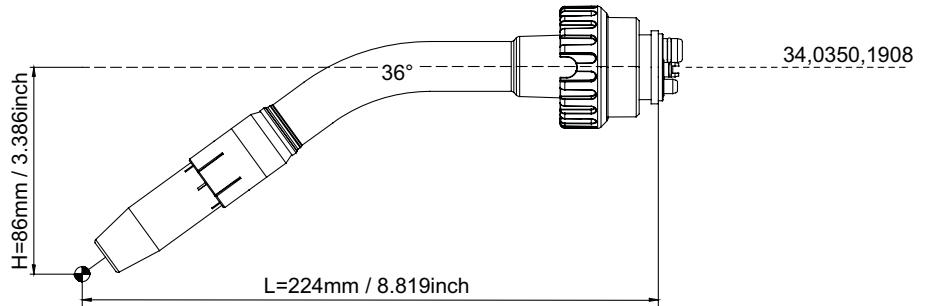
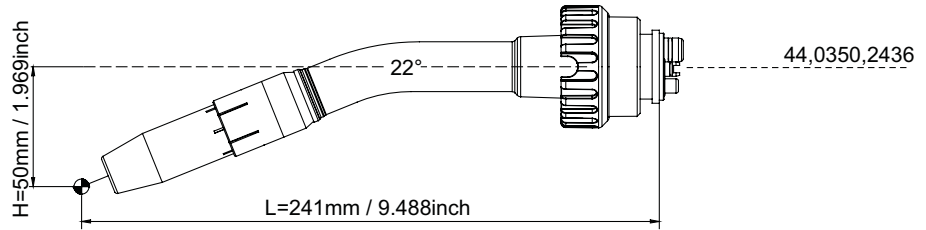
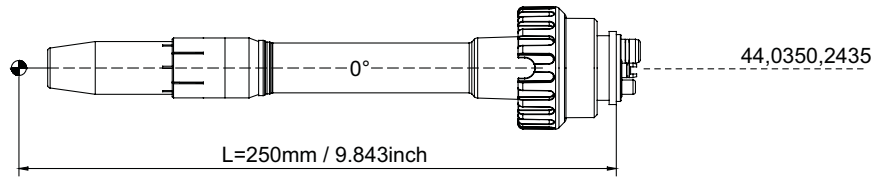

Robacta 400

Ersatzteilliste / Spare parts list / Listes de pièces de rechange / Lista de repuestos / Lista de peças sobresselentes / Lista dei Ricambi

ROBACTA 400 - OVT

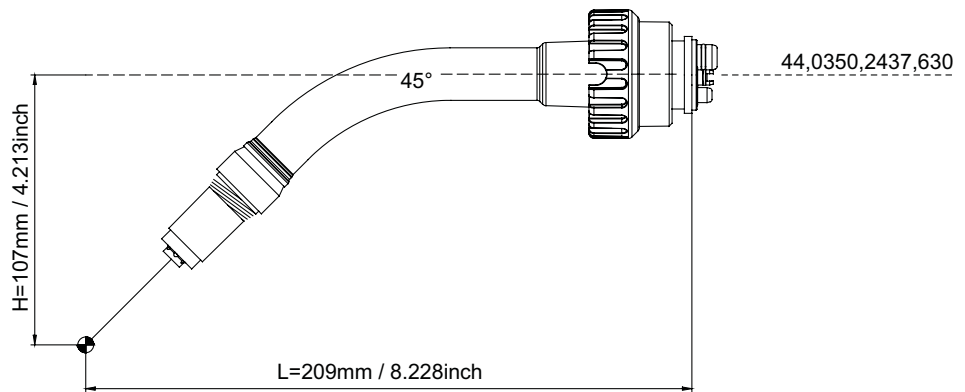
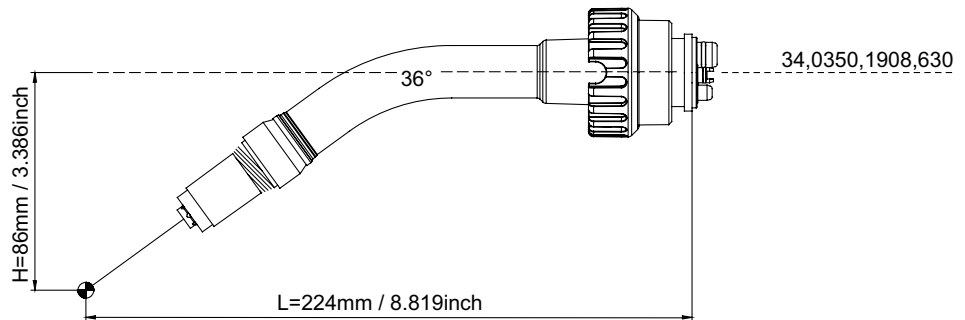
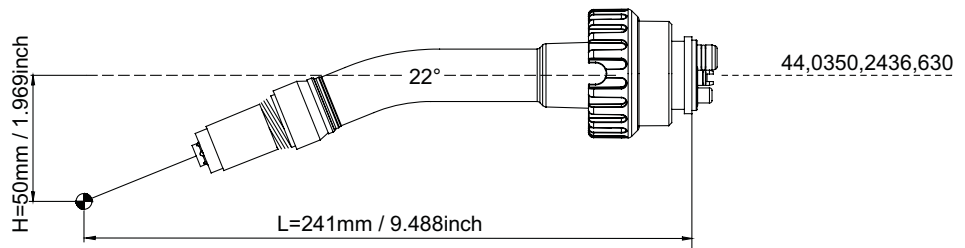
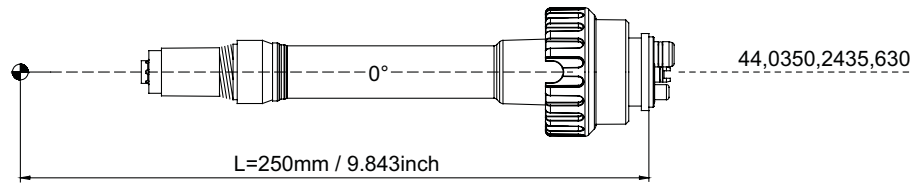

Robacta 400

Ersatzteilliste / Spare parts list / Listes de pièces de rechange / Lista de repuestos / Lista de peças sobresselentes / Lista dei Ricambi

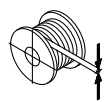
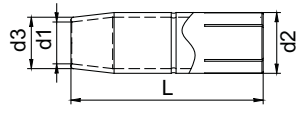
TAB. gas nozzle plugable	d1		d2		d3		L			Part No.
	mm	inch	mm	inch	mm	inch	mm	inch		
	11	.433	22	.866	17	.669	67	2.638	Fe,AlMg,AISI	42,0001,5151
	13	.512	22	.866	17	.669	67	2.638	Fe,AlMg,AISI	42,0001,5096 x)
	13	.512	22	.866	17	.669	65	2.559	CrNi/CuSi	42,0001,5619
	15,2	.598	22	.866	20	.787	67	2.638	Fe,AlMg,AISI	42,0001,5269
	17	.669	22	.866	22	.866	67	2.638	Fe,CrNi	42,0001,5821

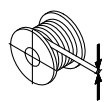
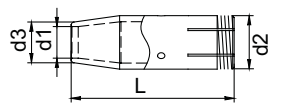
TAB. gas nozzle screwable	d1		d2		d3		L			Part No.
	mm	inch	mm	inch	mm	inch	mm	inch		
	13	.512	22	.866	17	.669	67	2.638	Fe,AlMg,AISI CrNi/CuSi	42,0001,5246

- x) Standardausrüstung
- x) standard equipment
- x) équipement standard
- x) equipamiento estándar
- x) accessori standard
- x) equipamento de série

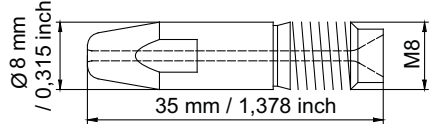
M8 / CuCrZr / L=35 mm (1,378 inch)	 Fe / CrNi		Part No.
	Ø mm	Ø inch	
	0,8	.031	42,0001,2911
	0,9	.035	42,0001,3082
	1,0	.039	42,0001,2912
	1,2	.047	42,0001,2913

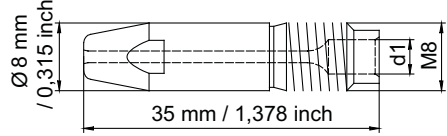
M8 / CuCrZr / L=35 mm (1,378 inch)	 Al CuSi		d1		Part No.
	Ø mm	Ø inch	Ø mm	Ø inch	
	0,8	.031	3,9	.154	42,0001,5082
	1,0	.039	4,1	.161	42,0001,5051
	1,2	.047	4,1	.161	42,0001,5052
	1,4	.055	4,1	.161	42,0001,5053
	1,6	.063	4,8	.189	42,0001,3485



Contact tip M8

Ersatzteilliste / Spare parts list / Listes de pièces de rechange / Lista de repuestos / Lista de peças sobresselentes / Lista dei Ricambi

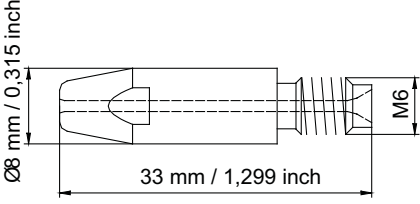
M6 / CuCrZr / L=33 mm (1,299 inch)	 Fe / CrNi CuSi / Al		Part No.
	Ø mm	Ø inch	
	0,6	.024	42,0001,0052
	0,8	.031	42,0001,0053
	0,9	.035	42,0001,3276
	1,0	.039	42,0001,0054
	1,2	.047	42,0001,0055
	1,4	.055	42,0001,1929
	1,6	.063	42,0001,0056

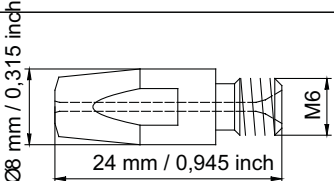
M6 / CuCrZr / L=24 mm (0,945 inch)	 Fe / CrNi CuSi / Al		Part No.
	Ø mm	Ø inch	
	0,8	.031	42,0001,1373
	1,0	.039	42,0001,1391
	1,2	.047	42,0001,1392
	1,6	.063	42,0001,1393



Contact tip M6

Ersatzteilliste / Spare parts list / Listes de pièces de rechange / Lista de repuestos / Lista de peças sobresselentes / Lista dei Ricambi

ZUBEHÖR ROBACTA (ACCESSORY)

Robacta & Robacta Twin

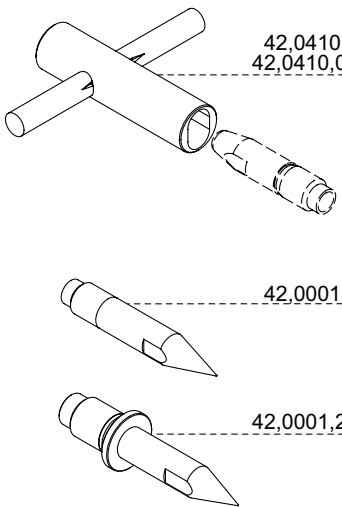

42,0410,0570-M8
42,0410,0138-M10

42,0001,2946-M8

42,0001,2920-M10

Robacta Twin

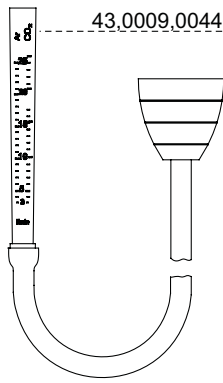

43,0009,0044

Robacta

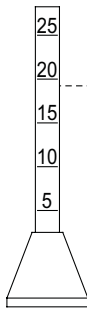

43,0009,0007

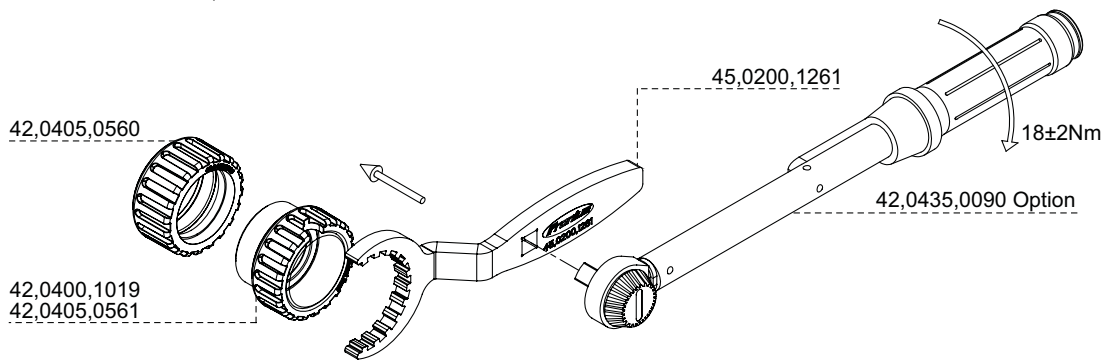

42,0405,0560

42,0400,1019
42,0405,0561

45,0200,1261

18±2Nm

42,0435,0090 Option

4,100,543 Touch Sensing Set

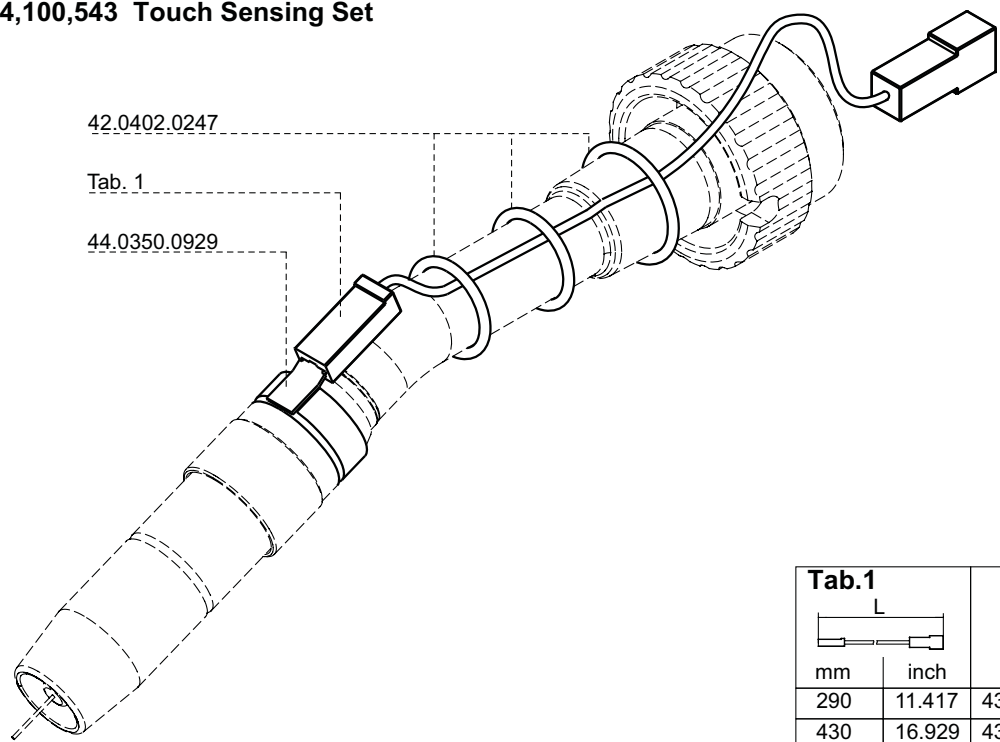

42,0402,0247

Tab. 1



44,0350,0929

mm		Part No.
mm	inch	
290	11.417	43.0004.3877
430	16.929	43.0004.3878

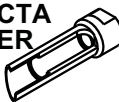

Accessories Robacta

Ersatzteilliste / Spare parts list / Listes de pièces de rechange / Lista de repuestos / Lista de peças sobresselentes / Lista dei Ricambi

Gas nozzle milling tool			ROBACTA REAMER 	
Type	 Ømm	 Øinch	Part No.	
Robacta 280	13	.512	44,0450,1158	+
	15	.591	44,0450,1385	+
Robacta 280 H	13	.512	44,0450,1158	+
	15	.591	44,0450,1159	++
Robacta 2500	10	.394	not possible	-
	12	.472	not available	-
	17	.669	44,0450,1161	+
Robacta 300	11	.433	not available	-
	13	.512	44,0450,1158	+
	15,2	.598	44,0450,1159	++
Robacta 400	11	.433	not available	-
	13	.512	44,0450,1158	+
	15,2	.598	44,0450,1385	+
Robacta 500	13	.512	not possible	-
	15	.591	44,0450,1160	+
	17,2	.677	44,0450,1255	++
Robacta 5000	13	.512	not possible	-
	15,2	.598	44,0450,1160	+
	17	.669	44,0450,1161	+
	17,2	.677	44,0450,1161	+
Robacta 5000H	17	.669	44,0450,1161	++
	20	.787	not available	-
Robacta 700	17	.669	44,0450,1255	++
Robacta 7000	17,2	.677	44,0450,1161	+

Robacta 900 Twin	14	.551	44,0450,1162	+
	18	.709	44,0450,1163	o
Robacta 900 Twin Compact	18	.709	44,0450,1163	o

Robacta MTG 2500	13	.512	44,0450,1158	+
	15	.591	44,0450,1159	++
Robacta MTG 3200	15	.591	44,0450,1385	+
Robacta MTG 4000	15	.591	44,0450,1160	+
	17	.669	44,0450,1255	++

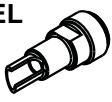
BINZEL 	
Part No.	
42,0001,5020	+
42,0001,5019	o
42,0001,5020	+
42,0001,3585	+
not possible	-
not available	-
42,0001,2996	o
not available	-
42,0001,5020	+
42,0001,3585	++
42,0001,3585	++
not available	-
42,0001,5020	+
42,0001,5019	o
42,0001,2996	o
not possible	-
42,0001,5019	+
42,0001,5545	++
not possible	-
42,0001,5019	+
42,0001,2996	+
not available	-
42,0001,2996	+
42,0001,5545	++
42,0001,5545	o

not possible	-
not possible	-
not possible	-

42,0001,5020	+
42,0001,3585	++
42,0001,5019	o
42,0001,5019	+
42,0001,5545	++

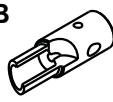
ABB 	
Part No.	
42,0001,5315	+
42,0001,5317	o
42,0001,5315	+
42,0001,5317	++
not possible	-
42,0001,5316	o
42,0001,5314	o
42,0001,5316	o
42,0001,5315	+
42,0001,5317	++
42,0001,5317	++
42,0001,5316	o
42,0001,5315	+
42,0001,5317	o
42,0001,5314	o
not possible	-
42,0001,5317	o
42,0001,5314	++
not possible	-
42,0001,5317	o
42,0001,5314	o
not available	-
42,0001,5314	+
42,0001,5314	++
42,0001,5314	o

not possible	-
not possible	-
not possible	-

42,0001,5315	+
42,0001,5317	++
42,0001,5317	o
42,0001,5317	o
42,0001,5314	++

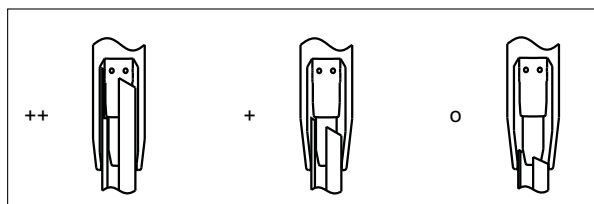

Gas nozzle milling tool



Gas nozzle milling tool

Ersatzteilliste / Spare parts list / Listes de pièces de rechange / Lista de repuestos / Lista de peças sobresselentes / Lista dei Ricambi

Examination device Robacta long

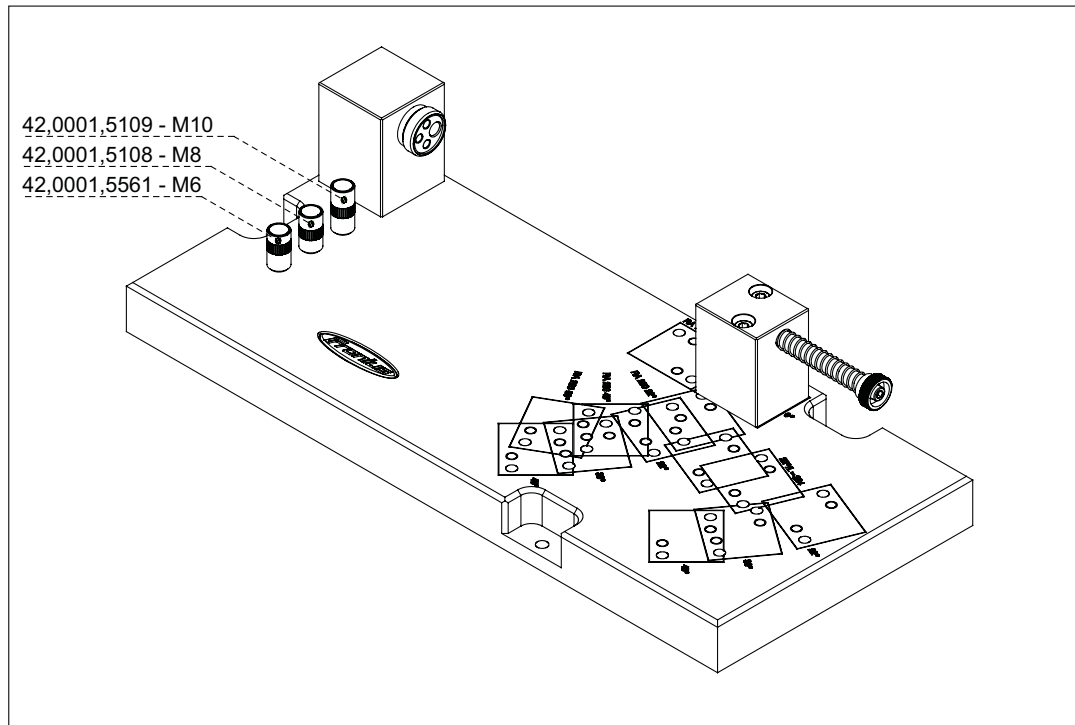

44.0360.0063

Been suitable for this Robacta types:

Type	Degree	Length	
		mm	inch
Robacta 160	0°	224,5	8,839
	22°	218,5	4,240
	45°	212,5	1,575
Robacta 280	0°	250	9,843
	22°	246	9,685
	45°	228,5	8,996
	60°	212,5	8,366
Robacta 300 Robacta 400	0°	250	9,843
	22°	241	9,488
	22°	324	12,756
	22°	382	15,039
	36°	224	8,819
Robacta 500	45°	209	8,228
	0°	250	9,843
	22°	241	9,488
	22°	383	15,079
	36°	224	8,819
Robacta 700 Robacta 7000	36°	366	14,409
	45°	209	8,228
	45°	351	13,819
	0°	187,5	7,382
	0°	250	9,843
	0° (Time)	258	10,157
	22°	241	9,488
36°	224	8,819	
Robacta 2500	36° (Time)	230,5	9,075
	45°	209	8,228
Robacta 5000	22°	241	9,488
	36°	224	8,819
	45°	209	8,228
	0°	250	9,843
	22°	241	9,488
Robacta 5000	22°	383	15,079
	36°	224	8,819
	36°	366	14,409
	45°	209	8,228
	45°	351	13,819



Examination device Robacta long

Ersatzteilliste / Spare parts list / Listes de pièces de rechange / Lista de repuestos / Lista de peças sobresselentes / Lista dei Ricambi

1 / 1

Correcting device Robacta (Basic Kit)

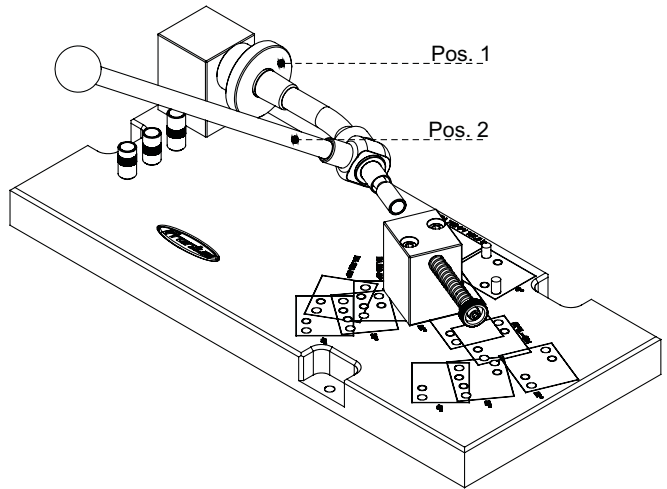
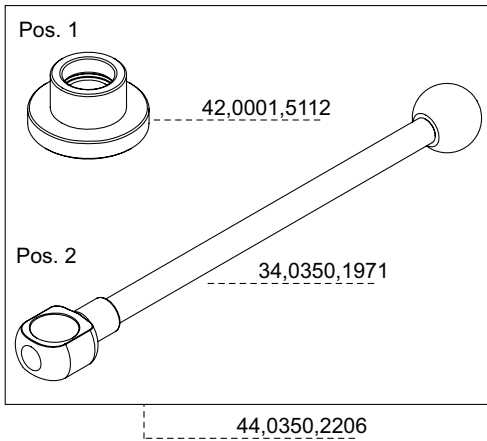

Correcting Set's

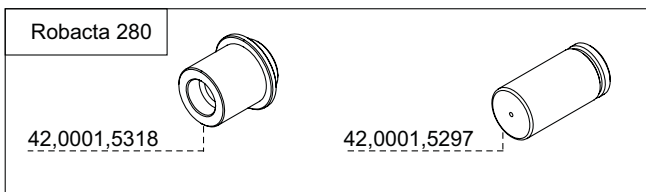

44,0350,1963 - Set

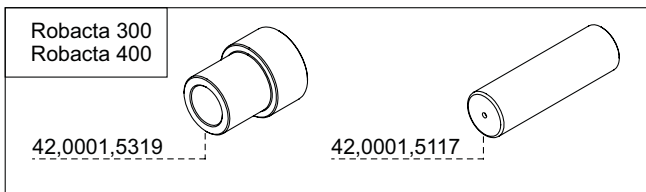

44,0350,1646 - Set

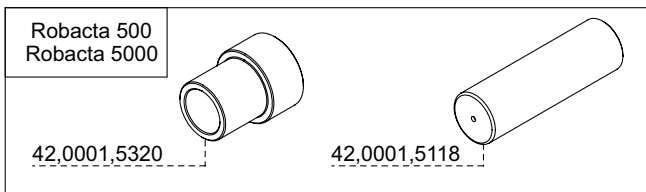

44,0350,1647 - Set

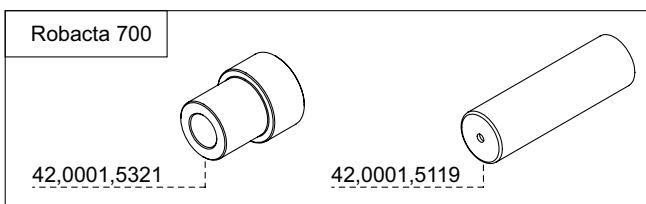

44,0350,1648 - Set

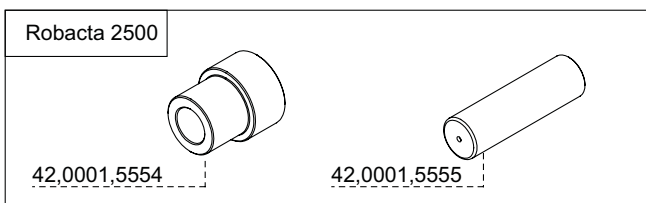

44,0350,2223 - Set

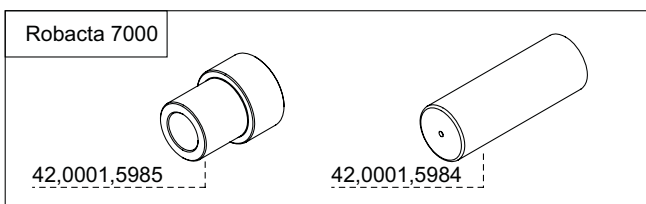

44,0350,2630 - Set

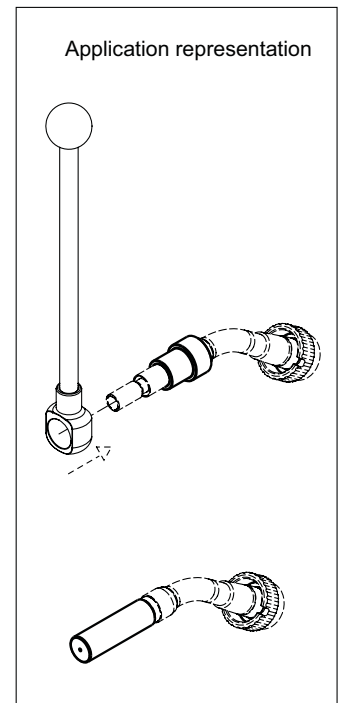

Robacta adjusting device

Ersatzteilliste / Spare parts list / Listes de pièces de rechange / Lista de repuestos / Lista de peças sobresselentes / Lista dei Ricambi



FRONIUS INTERNATIONAL GMBH

Buxbaumstraße 2, A-4600 Wels, Austria

Tel: +43 (0)7242 241-0, Fax: +43 (0)7242 241-3940

E-Mail: sales@fronius.com

www.fronius.com

www.fronius.com/addresses

Under <http://www.fronius.com/addresses> you will find all addresses
of our Sales & service partners and Locations.